



#### Main characteristics

- Absolute transducer
- Direct Serial Synchronous Interface to controllers
- Resolution from 5 to 40  $\mu\text{m}$  (2  $\mu\text{m}$  on request)
- Data format: binary or Gray code; incremental/decremental
- Strokes from 100 to 4000 mm
- Working temperature: -40...+70°C
- Resistance to vibrations (DIN IEC68T2/6 12g)
- Very compact
- IP67 protection
- Conforms to EC directives (EN 50081-2 50082-1)
- Power supply range 24Vdc  $\pm$  20%
- Max. working pressure 350 bar static, 700 bar peak

Absolute linear position transducer, contactless with magnetostrictive technology.

Sensor position data are coded in binary or Gray code and transmitted at high speed via Serial Synchronous Interface (SSI).

The SSI output supplies synchronization in a closed loop system.

Data from the sensor is timed with the clock supplied by the controller: one data bit is transmitted to the controller for each clock received from the sensor.

#### TECHNICAL DATA

Model	from 100 to 4000 mm
Measurement taken	shift
Position read sampling time	from 0.5 to 3 ms
Shock test DIN IEC68T2-27	100g - 11ms - single blow
Vibration DIN IEC68T2-6	12g / 10...2000Hz
Sliding cursor drag force	$\leq$ 1 N
Shift speed	$\leq$ 10 m/s
Max. acceleration	$\leq$ 100 m/s <sup>2</sup> shift
Resolution	5, 10, 20, or 40 $\mu\text{m}$ (2 $\mu\text{m}$ on request)
Magnet type	Sliding cursor Separate floating magnet
Rated power supply	24Vdc $\pm$ 20%
Max. power ripple	1 Vpp
Max. input	100mA typical
Output signal (connections side)	Serial Synchronous (SSI); binary/Gray; incremental/decremental
Load on output	RS 422/485 Standard
Electrical isolation	500V (D.C. power/ground)
Lunghezza dati	16 - 21 - 24 - 25 bit
Reverse polarity protection	YES
Overvoltage protection	Varistors on power line
Protection	IP67
Work temperature	-40...+70°C
Storage temperature	-40...+100°C
Coefficient of temperature	Typical 20 ppm/°C

#### MECHANICAL DIMENSIONS

##### Version IK2S B

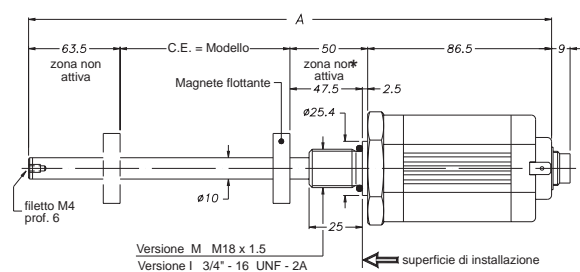

##### Hexagonal nut

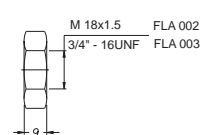

##### Version IK2S F

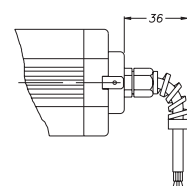

##### Floating magnets

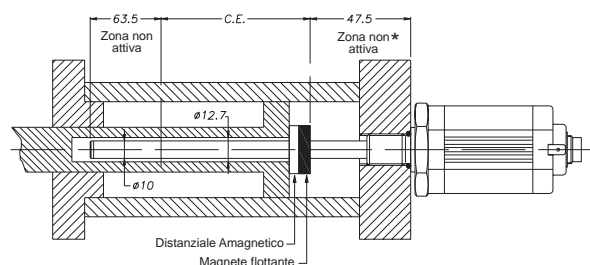
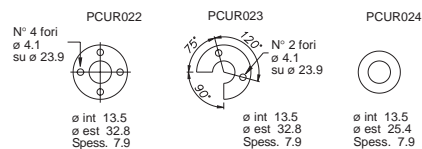

\* For the models from 2000 in then, to increase the quota 20mm.

## ELECTRICAL/MECHANICAL DATA

<b>Model</b>		100	130	150	200	225	300	400	450	500	600	700	750	800	900	1000	1250	1500	1750	2000	2250	2500	2750	3000	3250	3500	3750	4000		
Electrical stroke (C.E.)	mm	<b>Model</b>																												
Independent linearity	± %	0,03	0,025																										≤ 0,02 of C.E.	
Max. dimensions (A)	mm	Model + 200 (+220mm. from 2000 in then)																												
Repeatability	± %	0,001 of C.E.																												
Hysteresis	mm	< 0,01																												

## ORDER CODE

Position transducer	<b>IK2</b>	<b>S</b>				
Digital output (SSI)	<b>S</b>					
6-pin DIN 45322 output connector	<b>B</b>					
6-pin PVC cable output	<b>F</b>					
<b>Model</b>						
Binary data code output	<b>B</b>					
Gray code output	<b>G</b>					
Data length 16 Bit	<b>1</b>					
Data length 21 Bit	<b>2</b>					
Data length 24 Bit	<b>3</b>					
Data length 25 Bit	<b>4</b>					

Mechanical and/or electrical characteristics differing from those in the standard version may be arranged on request.

### ► Included in the supply

- Series IK position transducer
- OR 15.4 x 2.1 thread M18 x 1.5 code: **GUA064**
- OR 16.36 x 2.21 thread 3/4" -16 UNF code: **GUA065**

### ► Magnetic cursors must be ordered separately

- see cursors catalog

Ex.: **IK2-S-B-0400-B-3 0000-1-1-XX-X-00-M-0-XX**

Model IK2 transducer, SSI output, B connector, model 400, binary code output, data length 24 bits, system resolution 0.005 mm, ascending scale orientation, thread M18x1.5.

## Data transmission speed

Cable length	Baud Rate (Kbaud)
< 3	1,5 MBd
< 50	< 400 KBd
< 100	< 300 KBd
< 200	< 200 KBd
< 400	< 100 KBd

## CODE EXTENSION

<b>System resolution</b>	<b>Scale orientation</b>	<b>Thread</b>	<b>Cable length</b>
1 = 0.005 mm (standard)	1 = ascending (standard)	M = M18x1.5 (standard)	(standard version F 1 meter)
2 = 0.01 mm	2 = descending	I = 3/4" - 16 UNF	Output F 00=1mt 02=2mt 03=3mt 04=4mt 05=5mt
3 = 0.02 mm	Compared to electrical connections		Output B 00 10=10mt 15=15mt
4 = 0.04 mm			

GEFRAN spa reserved the right to make aesthetic or functional changes at any time and without notice.

## ELECTRICAL CONNECTIONS

### OUTPUT IK2S B

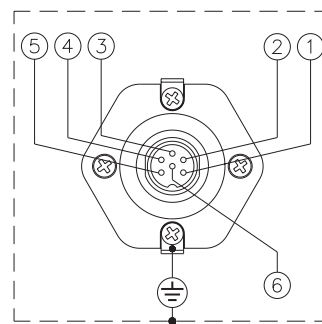

Pin. No.	Function
1	Data (-)
2	Data (+)
3	Clock (+)
4	Clock (-)
5	Power +Vdc
6	DC Ground

### ATTENTION!

Do not connect the DC Ground to the ground or to the cable sheathing.

### OUTPUT IK2S F

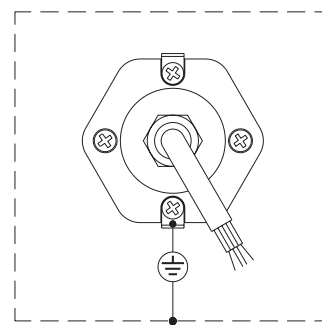

Filo	Function
Orange	Data (-)
Orange/White	Data (+)
Green/White	Clock (+)
Green	Clock (-)
Blu/Bianco	Power +Vdc
Blue	DC Ground

### ATTENTION!

Do not connect the DC Ground to the ground or to the cable sheathing.