

Main characteristics

- Absolute measurement of position and speed
- Possibility of one or two cursors simultaneously
- Local intelligence
- Interface: CANopen DS-301 V4.01 Device Profile DS-406 V2.0
- Strokes from 100 to 4000 mm
- Position resolution up to $2\mu\text{m}$
- Speed resolution up to 0.01 mm/sec
- Linearity error $\leq 0.01\%$
- Repeatability error $\leq 0.001\%$
- Conforms to EC directives (EN 50081-2 50082-1)
- Resistance to vibrations (DIN IEC68T2/6 12g)
- IP67 protection

Absolute linear position transducer, contactless for long mechanical life. Magnetostrictive technology for highest resolution and repeatability. The sealed IP67 structure makes the sensor suitable for use in hostile environments.

The MK2 CANopen integrates a microprocessor to process the measurement and to diagnose the transducer. The CAN field bus communication system provides fast and safe transmission. The use of CANopen DS-301 protocol and Device Profile DS-406 provides quick and easy integration of the transducer in the control and automation system.

TECHNICAL DATA

Model	from 100 to 4000 mm
Measurement taken	linear position and speed
Position read sampling time	from 1 to 4 ms (depending on length)
Shock test DIN IEC68T2-27	100g - 11ms - single blow
Vibration DIN IEC68T2-6	12g / 10...2000Hz
Sliding cursor drag force	$\leq 1\text{ N}$
Shift speed	$\leq 10\text{ m/s}$
Max. acceleration	$\leq 100\text{ m/s}^2$ shift
Resolution	$5\mu\text{m}$ ($2\mu\text{m}$ on request)
Cursor	Floating ring with integrated magnets
Rated power supply	24Vdc $\pm 20\%$
Max. power ripple	1 Vpp
Max. input	100mA typical
Output signal	CAN bus digital communication
Electrical isolation	500V (D.C. power/ground)
Reverse polarity protection	YES
Overvoltage protection	Varistors on power line
Overcurrent protection	PTC (self-resettable fuse on power line)
Environmental protection	IP67
Work temperature	$-40\dots+70^\circ\text{C}$
Storage temperature	$-40\dots+100^\circ\text{C}$
Coefficient of temperature	Typical $20\text{ ppm}/^\circ\text{C}$

MECHANICAL DIMENSIONS

Version MK2C B/M with sliding magnetic cursor

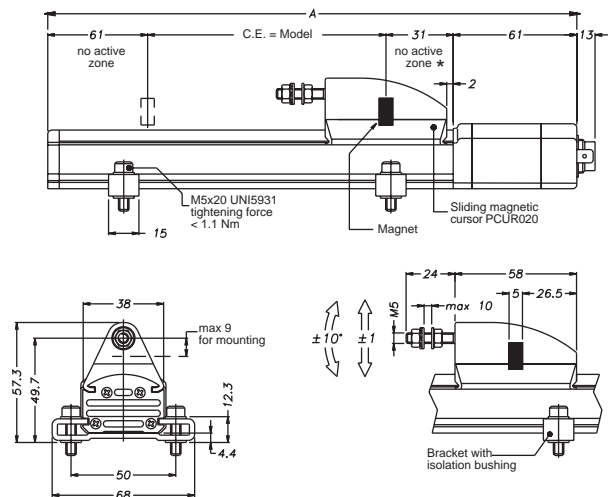

Version MK2C F with floating magnetic cursor

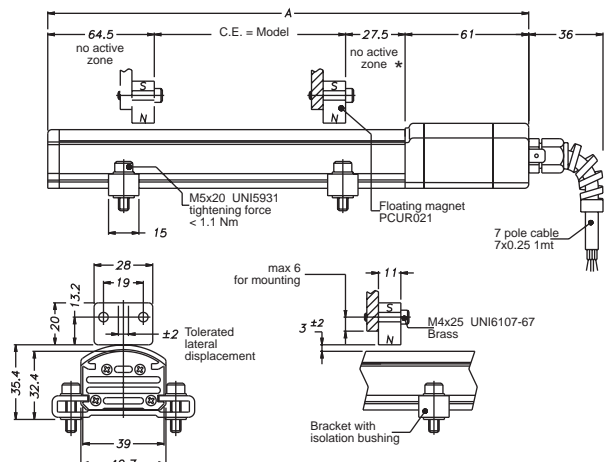

* For the models from 2000 in then, to increase the quota 20mm.

ELECTRICAL/MECHANICAL DATA

Model		100	130	150	200	225	300	400	450	500	600	700	750	800	900	1000	1250	1500	1750	2000	2250	2500	2750	3000	3250	3500	3750	4000			
Electrical stroke (C.E.)	mm	Model																													
Independent linearity	± %	0,03	0,025																									≤ 0,02 of C.E.			
Max. dimensions (A)	mm	Modello + 153 (+173mm. from 2000 in then)																													
Repeatability	± %	0,001 of C.E.																													
Hysteresis	mm	< 0,01																													

ELECTRICAL CONNECTIONS

Function	Connect. (B) Pin°	Connect. (M) Pin°	Cable (Wire Color)
CAN L	1	5	Blue
CAN H	2	4	White
Shield (CAN GND)	3	1	Sheathing
n.c.	4	-	-
Power + Vdc	5	2	Red
DC Ground	6	3	Black

ATTENTION! Do not connect the DC Ground to the ground or to the cable sheathing.

ORDER CODE

Position transducer **MK2** **C**

CANopen interface	C
6-pin DIN 45322 output connector	B
5-pin Micro type M12 output connector	M
4-pin braided cable (on request)	F

Model _____

Type (see table 1) _____

Transmission speed (see table 2) _____

Type	No. Cursors	PD01 (Standard)	PD02 (Standard)
A	1	Position 4 Byte whole Speed 2 Byte whole Cams 1 Byte whole	Absence of data
B	2	Position 1, 4 Byte whole Speed 2 Byte whole Cams 1 Byte whole	Position 2, 4 Byte whole Speed 2 Byte whole Cams 1 Byte whole

1 = 1MBaud	4 = 250 kBaud	7 = 50 kBaud
2 = 800 kBaud	5 = 125 kBaud	8 = 20 kBaud
3 = 500 kBaud	6 = 100 kBaud	9 = 10 kBaud

Mechanical and/or electrical characteristics differing from those in the standard version may be arranged on request.

Ex.: **MK2-C-B-0400-A-3 0000-2-XXXX-00-X-0-XX**
 Transducer model MK2, CANopen output, connector B, model 400, type A (one cursor), transmission speed 500 Kbaud.

► **Included in the supply**

- Series MK position transducer
- Fastening brackets with insulating bushes and screws

► **Magnetic cursors must be ordered separately**

- Sliding magnetic cursor code: **PCUR020**
- Floating magnetic cursor code: **PCUR021**

CODE EXTENSION

0	0	0	0	<input type="checkbox"/>	X	X	X	X	<input type="checkbox"/>	<input type="checkbox"/>	X	0	X	X
System resolution					Cable length									
1 = 0.002 mm					Output F 00 = 1mt 02 = 2mt 03 = 3mt 04 = 4mt 05 = 5mt									
2 = 0.005 mm (standard)					Output B 00									
3 = 0.010 mm					Output M 00									
4 = 0.020 mm														
5 = 0.040 mm														

Transmission speed as function of cable length

Cable length	Baud Rate (Kbaud)	Cable length	Baud Rate (Kbaud)
< 25 m	1000	< 500 m	125
< 50 m	800	< 1000 m	100
< 100 m	500	< 1250 m	50
< 250 m	250	< 2500 m	20 / 10

Can Open Data Protocol

SOFF	Arbitration	Control	Data Field	CRC	ACK	EOF	Interframe Space
1	11	1	6	0 - 8 Bytes	15	1 1 1	7
							≥ 3 Bits

GEFRAN spa reserved the right to make aesthetic or functional changes at any time and without notice.