



Main features

- 50 to 1000 mm. strokes
- Cursor magnetic drag
- Independent linearity $\pm 0,05\%$
- Repeatability: 0.08 mm
- Hysteresis: 0.25 mm
- Infinite Resolution
- No variation of electrical output signal outside theoretical electrical stroke
- Working temperature: $-30...+100^{\circ}\text{C}$
- Electrical connection: 3-pole polyurethane screened cable with high flexibility (1m lenght)
- Lifetime: $> 25 \times 10^6$ meters or $> 100 \times 10^6$ operations, whichever is the smallest (within C.E.U.)
- IP67 waterproof, (IEC 60529)
- Suitable for pneumatic applications with working pressures max. 20bar, 50bar peak

Rectilinear potentiometric displacement transducer without dragging shaft; completely waterproof (IP67); designed to work whether in wet environments or temporarily submerged (IEC 60529). The PME series is characterised by an external magnetic actuator coupled with an internal measurement cursor. The magnetic cursor substitutes the dragging tree used in the traditional displacement transducers; by this way, the overall dimensions are smaller.

TECHNICAL DATA

Useful electrical stroke (C.E.U.)	50 to 1000 mm
Independent linearity (within C.E.U.)	see table
Displacement speed	≤ 5 m/s
Max. acceleration	$\leq 10\text{m/s}^2$ displacement
DIN vibration IEC 68T2-6	12g, 10...2000Hz
Cursor dragging force	$\leq 0,5$ N
Shock test DIN IEC68T2-27	50 g, 11ms. single shock
Displacement sensitivity (no hysteresis)	from 0.05 to 0.1 mm
Tolerance on resistance	$\pm 20\%$
Recommended cursor current	$< 0,1$ μA
Maximum cursor current in case of bad performances	10mA
Maximum applicable voltage	see table
Electrical isolation	$> 100\text{M}\Omega$ at 500V~, 1bar, 2s
Dielectric strenght	< 100 μA at 500V~, 50Hz, 2s, 1bar
Dissipation at 40°C (0W at 120°C)	see table
Enviromental protection	IP 67
Actual temperature coefficient of the output voltage	$< 1,5\text{ppm}/^{\circ}\text{C}$
Working temperature	$-30...+100^{\circ}\text{C}$
Storage temperature	$-50...+120^{\circ}\text{C}$

MECHANICAL DIMENSION

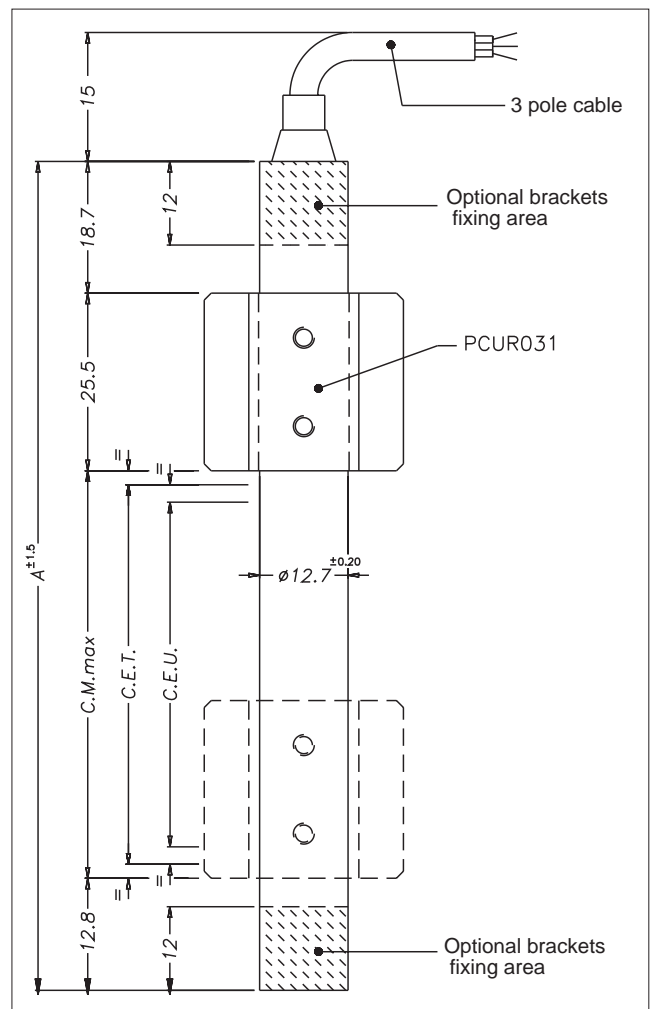

Importante: All the data reported in the catalogue linearity and temperature coefficients are valid for sensor utilization as a ratiometric device with a max. current across the cursor circuit $I_c \leq 0.1$ μA .

MECHANICAL / ELECTRICAL DATA

MODEL		50	100	150	200	250	300	350	400	450	500	550	600	650	700	750	800	850	900	950	1000
Useful electrical stroke (C.E.U.) + 1 / - 0	mm	Model																			
Theoretical electrical stroke (C.E.T.) ± 1	mm	C.E.U. + 1																			
Resistance (C.E.T.)	kΩ	5					10					20									
Independent linearity (within C.E.U.)	±%	0,1		0,05																	
Dissipation at 40°C (0W at 120°C)	W	1	2	3																	
Max applicable voltage	V	40		60																	
Mechanical stroke (C.M)	mm	C.E.U. + 5																			
Case Length (A)	mm	C.E.U. + 61,5																			

PCUR031 CURSOR

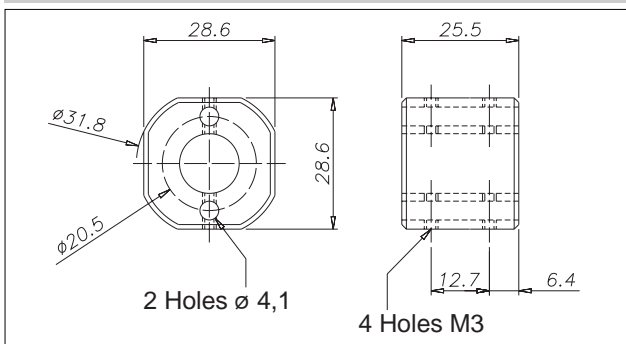

STA001 BRACKETS

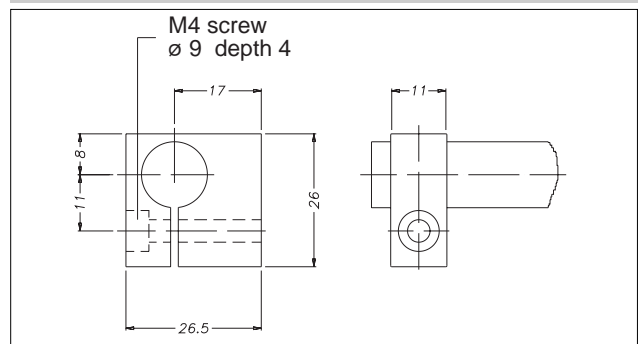

ELECTRICAL CONNECTIONS

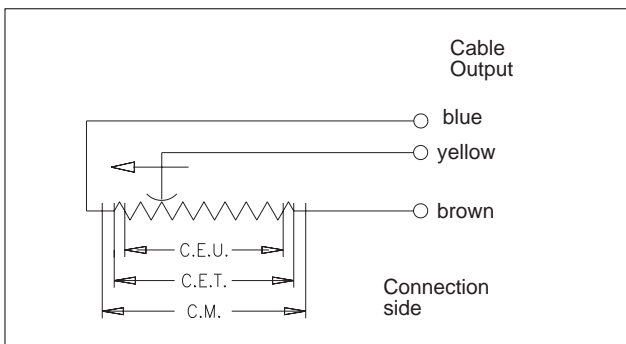

ORDER CODE

Displacement transducer **PME** 12 F S

Dimension 1/2"

3-pole PVC cable output 3x0,25 1m

Model

Brackets

If requested, it is possible to supply models with non-standard mechanical and/or electrical features

Example: **PME-12-F-400-S 0000-X000-XX-00-XXX**
 PME12 model transducer, useful electrical stroke (C.E.U.) 400mm, mounting by brackets.

TRACKING ERROR

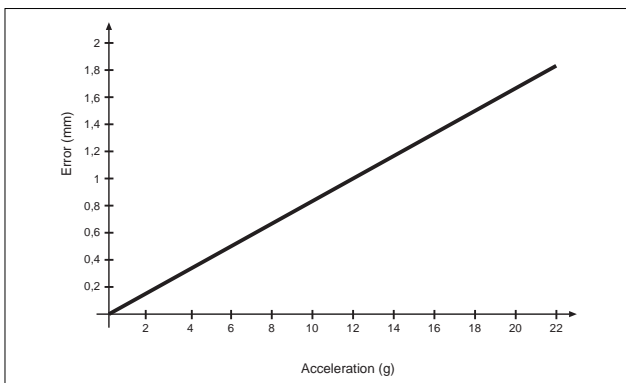

Included in the delivery

- Displacement Transducer PME series
- N° 2 Fixing brackets code: **STA001**
- N° 1 Magnetic cursor code: **PCUR032**

CODE EXTENSION

0 0 0 0 X 0 0 0 X X 0 0 X X X

CABLE LENGTH (1mt F standard version)
 F output 00 =1mt 02 =2mt 03 =3mt 04 =4mt 05 =5mt
 10 =10mt 15 =15mt

GEFRAN spa reserves the right to make any kind of design or functional modification at any moment without prior notice



GEFRAN spa
 via Sebina, 74
 25050 PROVAGLIO D'ISEO (BS) - ITALIA
 tel. 0309888.1 - fax. 0309839063
 Internet: <http://www.gefran.com>
www.gefranonline.com