



Main features

- 50 to 750 mm. stroke
- Mechanical fixing and selfaligning linkage using 2 ball-joints
- Maximum angular movement up to $\pm 30^\circ$
- Independent linearity $\pm 0,05\%$
- Repetibility 0,01 mm.
- Infinite resolution
- No variation of electrical signal outside theoretical electrical stroke
- Displacement speed up to 5 m/s
- Working temperature: $-30...+100^\circ\text{C}$
- Electrical connections:
PC H 3-pole connector
PC M 4-pole connector to standard DIN43650-ISO4400
PC B 5-pole connector (DIN43322)
PC F 3-pole screened cable (1 m length)
- Life duration: $> 25 \times 10^6$ meters or $> 100 \times 10^6$ operations, whichever is the smaller (within C.E.U.)
- Grade of protection IP65

TECHNICAL DATA

Useful electrical stroke (C.E.U.)	50/100/130/150/175/200/225/275/ 300/375/400/450/500/600/750
Independent linearity (within C.E.U.)	$\pm 0,05\%$
Displacement speed	≤ 5 m/s
Displacement force	≤ 10 N
Vibrations	5...2000Hz, $A_{max} = 0,75$ mm $a_{max} = 20$ g
Shock	50 g, 11ms.
Tolerance on resistance	$\pm 20\%$
Recommended cursor current	$< 0,1 \mu\text{A}$
Maximum cursor current	10mA
Maximum applicable voltage	60V
Electrical isolation	$> 100\text{M}\Omega$ at 500V~, 1bar, 2s
Dielectri strength	$< 100 \mu\text{A}$ at 500V~, 50Hz, 2s, 1bar
Dissipation at 40°C (0W at 120°C)	3W
Temp. Coeffi. of the resistance	$-200 \pm 200\text{ppm}/^\circ\text{C}$
Actual Temperature Coefficient of the output voltage	$< 1,5\text{ppm}/^\circ\text{C}$
Working temperature	$-30...+100^\circ\text{C}$
Storage temperature	$-50...+120^\circ\text{C}$
Case material	Anodised aluminium Nylon 66 GF 40
Control rod material	Stainless steel AISI 303
Fixing	2 selfloading and selfaligning ball-joints

MECHANICAL DIMENSIONS

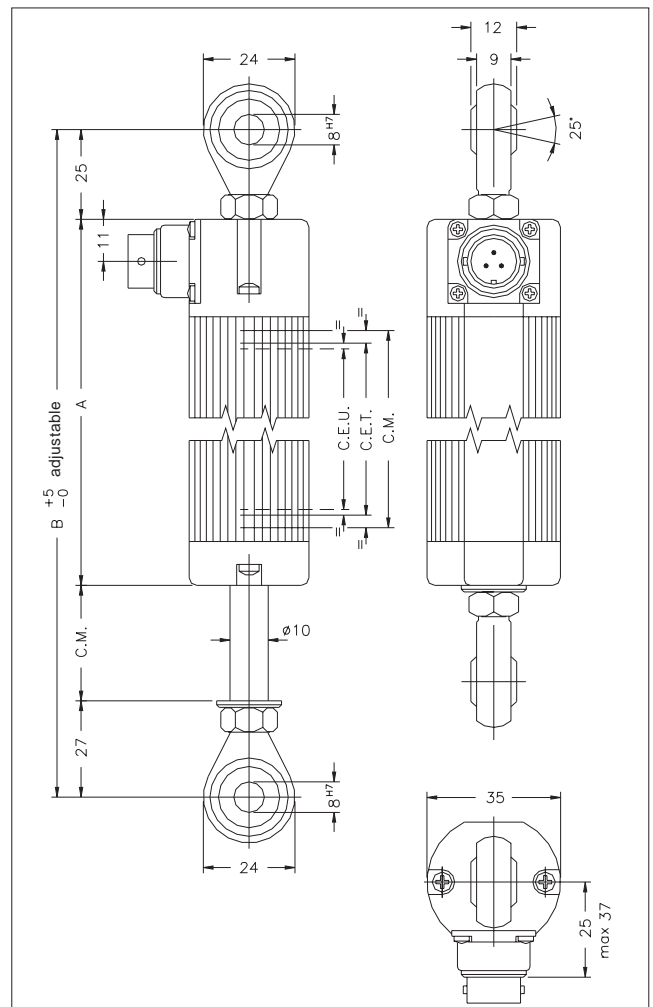

Important: all the data reported in the catalogue linearity, lifetime, temperature coefficient are valid for a sensor utilization as a ratiometric device with a max current across the cursor $I_c \leq 0.1 \mu\text{A}$.

MECHANICAL / ELECTRICAL DATA

MODEL		50	100	130	150	175	200	225	275	300	375	400	450	500	600	750	
Useful electrical stroke (C.E.U.) +3/-0	mm	50	100	130	150	175	200	225	275	300	375	400	450	500	600	750	
Theoretical electrical stroke (C.E.T.) ± 1	mm	C.E.U. + 3					C.E.U. + 4					380	406	457	508	609	762
Resistance (C.E.T.)	kΩ	5					5					5	5	5	5	5	10
Mechanical stroke (C.M.)	mm	C.E.U. + 9					C.E.U. + 10					386	412	463	518	619	772
Case length (A)	mm	C.E.U. + 129					C.E.U. + 130					512	538	589	664	765	918
Min. distance between ball-joints (B)	mm	C.E.U. + 181					C.E.U. + 182					564	590	641	716	817	970

ELECTRICAL CONNECTIONS

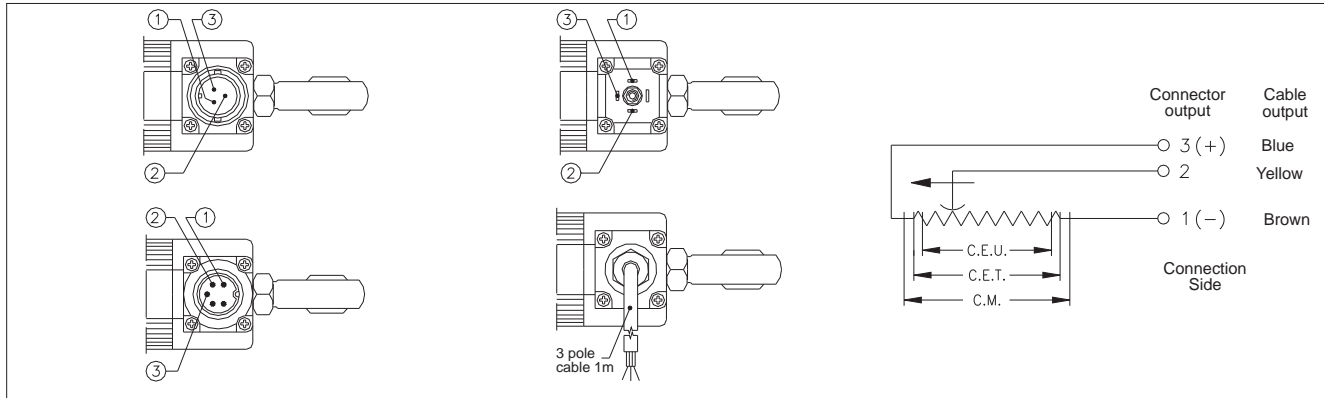

OPTIONAL ACCESSORIES

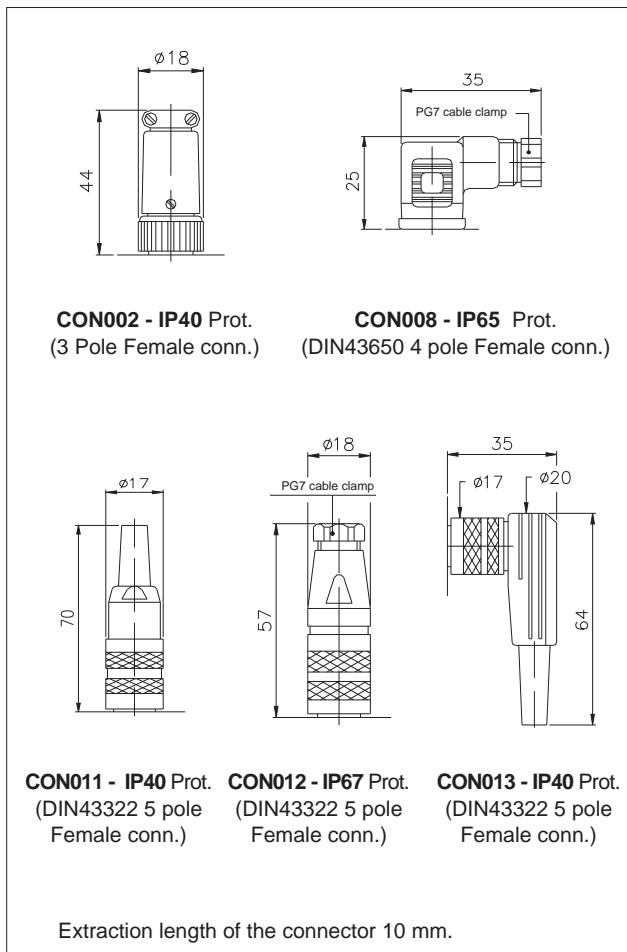

ORDER CODE

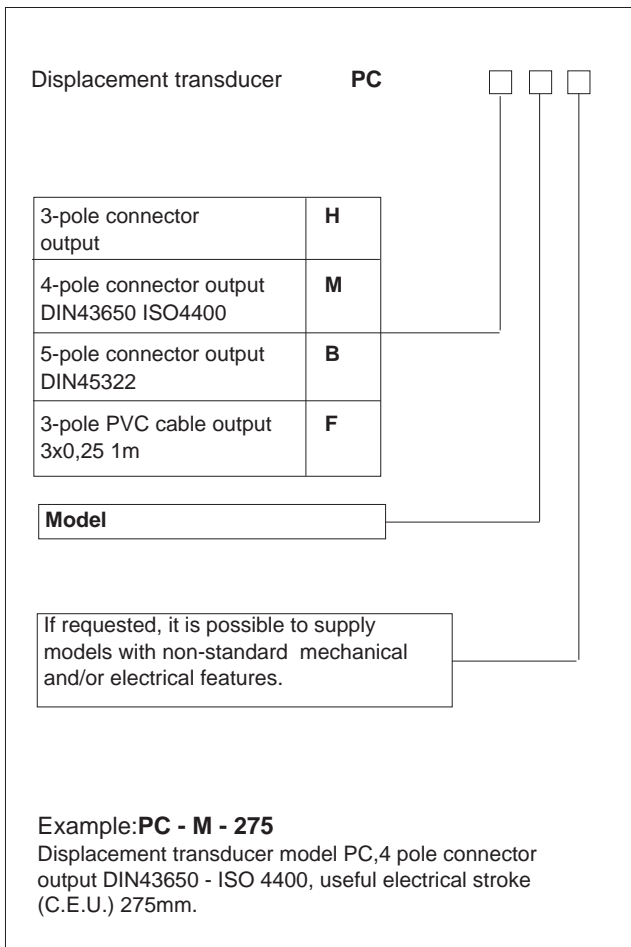

GEFRAN spa reserves the right to make any kind of design or functional modification at any moment without prior notice



GEFRAN spa
via Sebina, 74
25050 PROVAGLIO D'ISEO (BS) - ITALIA
ph. 0309888.1 - fax. 0309839063
Internet: <http://www.gefran.com>
www.gefranonline.com



cod.84863-10/00