

PZ12

RECTILINEAR DISPLACEMENT TRANSDUCER
WITH CYLINDRICAL CASE



Main features

- 25 to 150 mm. stroke
- Mechanical fixing using brackets, selfaligning ball-joints or flange
- Independent linearity up to $\pm 0,05\%$
- Infinite resolution
- No variation of electrical signal outside theoretical electrical stroke
- Displacement speed up to 10 m/s
- Working temperature: $-30...+100^{\circ}\text{C}$
- Electrical connection: 3-pole screened cable (1m length)
- Life duration: $> 25 \times 10^6$ meters or $> 100 \times 10^6$ operations whichever is the smaller (within C.E.U.)
- Grade of protection IP60

TECHNICAL DATA

Useful electrical stroke (C.E.U.)	25/50/75/100/125/150
Independent linearity (within C.E.U.)	see table
Displacement speed	≤ 10 m/s
Displacement force	$\leq 0.5\text{N}$
Vibrations	5...2000Hz, $A_{\text{max}} = 0,75$ mm $a_{\text{max}} = 20$ g
Shock	50 g, 11ms.
Tolerance on resistance	$\pm 20\%$
Recommended cursor current	$< 0,1 \mu\text{A}$
Maximum cursor current	10mA
Maximum applicable voltage	see table
Electrical isolation	$> 100\text{M}\Omega$ at 500V~, 1bar, 2s
Dielectric strength	$< 100 \mu\text{A}$ at 500V~, 50Hz, 2s, 1bar
Dissipation at 40°C (0W at 120°C)	see table
Temp. Coeff. of the resistance	$-200 \pm 200\text{ppm}/^{\circ}\text{C}$
Actual Temperature Coefficient of the output voltage	$< 1,5\text{ppm}/^{\circ}\text{C}$
Working temperature	$-30...+100^{\circ}\text{C}$
Storage temperature	$-50...+120^{\circ}\text{C}$
Case material	Anodised aluminium Nylon 66 GV 40
Control rod material	Stainless steel AISI 303
Fixing	Brackets, selfaligning ball-joints or flange

MECHANICAL DIMENSIONS

PZ12-S

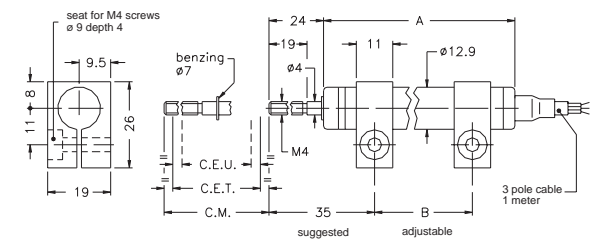

PZ12-A

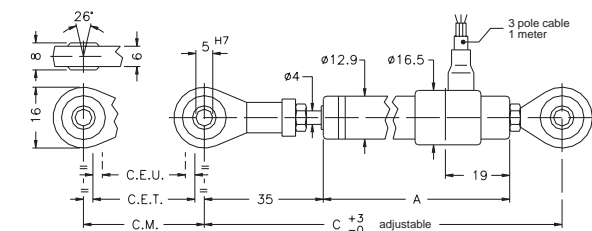

PZ12-F

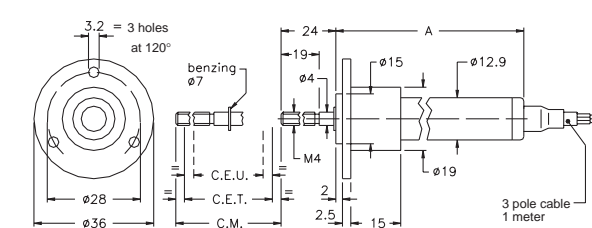

Important: all the data reported in the catalogue linearity, lifetime, temperature coefficient are valid for a sensor utilization as a ratiometric device with a max current across the cursor $I_c \leq 0.1 \mu\text{A}$.

MECHANICAL / ELECTRICAL DATA

MODEL		25	50	75	100	125	150	
Useful electrical stroke (C.E.U.) + 1 / -0	mm	25	50	75	100	125	150	
Theoretical electrical stroke (C.E.T.) ± 1	mm	C.E.U. +1						
Resistance (C.E.T.)	kΩ	1	2	3	4	5	6	
Independent linearity (within C.E.U.)	± %	0,2	0,1	0,1	0,1	0,05	0,05	
Dissipation at 40°C (0W at 120°C)	W	0,5	1	1,5	2	2,5	3	
Maximum applicable voltage	V	20	40	60				
Mechanical stroke (C.M.)	mm	C.E.U. +5						
Case length (A)	mod. PZ12 - S	mm	74,5	99,5	124,5	149,5	174,5	199,5
	mod. PZ12 - A	mm	102	127	152	177	202	227
	mod. PZ12 - F	mm	74,5	99,5	124,5	149,5	174,5	199,5
Recommended distance between brackets (B)	mm	42	67	92	117	142	167	
Minimum distance between ball-joints (C)	mm	153	178	203	228	253	278	
Weight	mod. PZ12 - S	g	45	55	65	75	85	95
	mod. PZ12 - A	g	70	80	90	100	110	120
	mod. PZ12 - F	g	60	70	80	90	100	110

ELECTRICAL CONNECTIONS

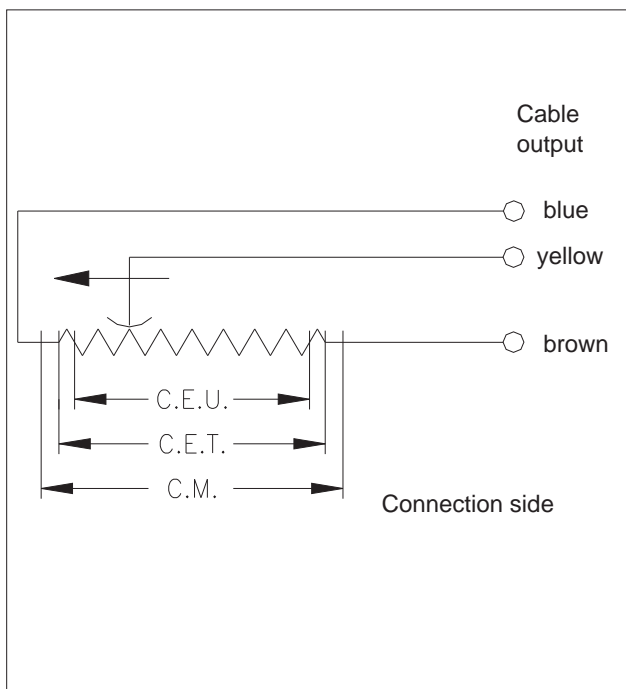

STANDARD ACCESSORIES

	Code
2 mounting brackets for PZ12-S	STA074

ORDER CODE

Displacement transducer **PZ12**

Mounting by brackets	S
Mounting by selfaligning ball-joints	A
Mounting by flange	F

Model

If requested, it is possible to supply models with non-standard mechanical and/or electrical features

Example: **PZ12 - S - 25**
 Displacement transducer model PZ12, mounting by brackets, useful electrical stroke (C.E.U.) 25mm

GEFRAN spa reserves the right to make any kind of design or functional modification at any moment without prior notice



GEFRAN spa
 via Sebina, 74
 25050 PROVAGLIO D'ISEO (BS) - ITALIA
 ph. 0309888.1 - fax. 0309839063
 Internet: <http://www.gefran.com>
www.gefranonline.com



cod. 84875-10/99