

# EMC-D3b

## Energy Multifunction Counter

### GENERAL

#### AVAILABLE MODELS

It's manufactured with a DIN rail mounting case 6 modules 17.5 mm.

#### INTRODUCTION

The EMC-D3b allows the local visualisation of the energy, so as the remote counting of the energy, with the help of a serial interface. The auxiliary power supply is taken from same Voltage inputs, used for measuring.



#### OPTIONS and ACCESSORIES

- options:**
- serial interface RS485 with MODBUSRTU protocol.
  - with internal CT's ( for insulation purpose only)
  - power supply and measuring voltages other than the standard.

#### MEASURED PARAMETERS

Parameters	Unit of measure	Identifying abbreviations
Three phase system active energy	[kWhr]	kWh
Three phase system reactive energy	[kVArhr]	kVArh

#### INSTALLATION

##### Notes to the user

Read carefully the instructions in this manual before installing the present instrument.  
The instrument described in this manual is intended for being used only by properly trained staff.

##### Safety

This instrument has been manufactured and tested according to EN 61010-1 (IEC 1010) standards. In order to maintain these conditions and to ensure safe operation, the users must follow the instructions of this manual.

Before the installation, check that it's still intact and no damage has been suffered during transport and make sure that the operating voltage and main voltage are compatible with the device instructions.

The instrument power supply must not be earthen. Only qualified and authorised staff must carry out maintenance and/or repair. Should it be considered that there is a safety loss during operation, the instrument must be disconnected and precautions taken against accidental use.

The operation is not safe when:

The instrument doesn't work / the instrument shows clearly visible damages / after severe damages due to the transport / after a long time storing under unfavourable ambient conditions.

An external protection should be foreseen, by means of a 0.5 A 250V fuse at the voltage inputs. Use adequate cables for the working current and voltage, with a cross section of 0.5 to 2.5 mm<sup>2</sup>.

## WIRING

For a correct use of the instrument, the wiring descriptions and diagrams should be respected. The wiring will be made at the side screw terminals available.

### - Auxiliary Power Supply:

The power supply is taken from the measuring voltage inputs VL1 y VL2.

The rated power supply is 400Vac = 380 ±415Vac 50-60 Hz

### - VOLTAGE INPUT MEASURE

### - Measuring voltage inputs:

4 screw terminals are available for the 3 phase plus neutral system network. The maximum voltage between phase to phase must not overcome 500 Vrms., depending always on the instrument's power supply.

In case of three phase application with or without neutral not distributed, it is enough not to connect the terminal N.

### - Measuring current inputs:

6 screw terminals are available for the connection of the external CT with secondary 5A. It's compulsory to use external CT's.

It is also possible to use 2 CT in a three phase system (3Phase Aaron wiring system)

The transformation ratio of the external CT's can be set on the instrument's SETUP menu.

### NOTE:

It's fundamental to respect the correct phase sequence. The connections between current and voltage phase inputs must not be inverted (for example, CT placed on phase L1 must correspond to the I1 input) and at the same time it's not correct to invert the S1 and S2 terminals considering that the energy metering won't be reliable.

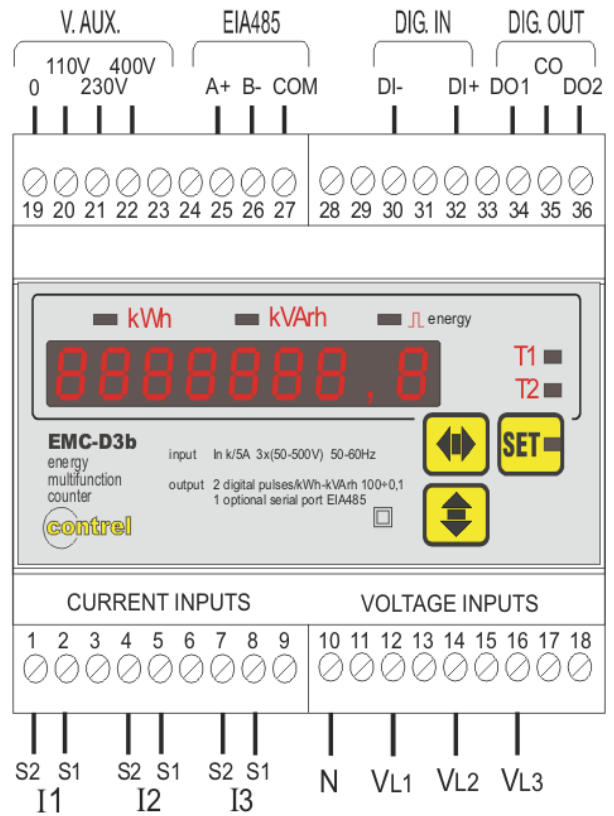

## WIRING DIAGRAM

### THREE PHASE WIRING WITH 3 or 4 WIRES

In a 3 wires line (without neutral or not distributed neutral) DON'T connect the N terminal

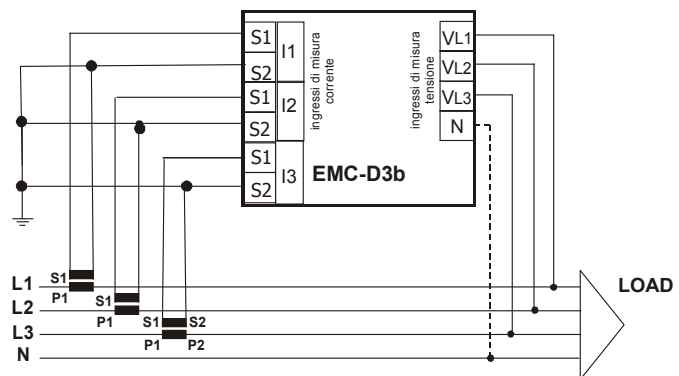

## FRONT PANEL DESCRIPTION – KEYS

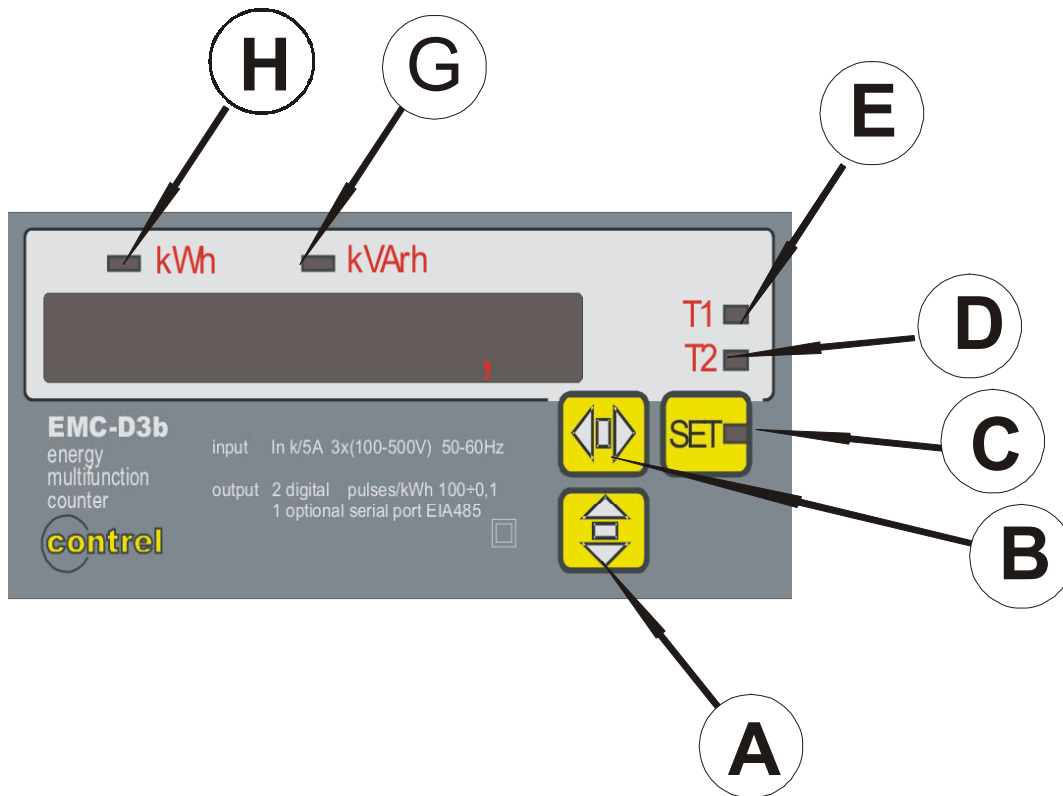

### DESCRIPTION:

- A:** Push-button key for selecting the energy visualisation / for decreasing values when setting at SETUP
- B:** Push-button key for selecting the energy visualisation / for increasing values when setting at SETUP
- C:** Push-button key to reach the programming mode; hold the push-button pressed for 5 seconds to switch the associated LED on, which will advise that the SETUP mode is active.
- D:** LED for indication of the T1 time band energies. Should it be blinking, it means that the energy counting is being accumulated on time band 1.
- E:** LED for indication of the T2 time band energies. Should it be blinking, it means that the energy counting is being accumulated on time band 2.
- G:** LED for indication of reactive energy counting.
- H:** LED for indication of active energy counting.

### INSTRUMENT'S PROGRAMMING MENU (SETUP)

By holding the **C** key pressed for over 5 seconds, we get to the programming of the instrument.

The programs, confirmed with the **C** key are kept memorised, whilst the performed modifications won't be kept memorised, if they have not been confirmed with the **C** key. Once that 8 seconds have elapsed from the last pressure to any key, the instrument comes back to energies visualisation.

The instrument's parameters can be programmed with the **SETUP** menu, or either cancelling the energy counters with the **RESET** menu.

Possible programming from the **SETUP** menu:

<b>CT_XXXX</b>	setting of the CT's transformation ratio
<b>PUL_XXX</b>	setting of the pulse weight in 10-100-1000-10000 W (Var) h / pulse
<b>tPL_XXX</b>	setting of the pulse duration 100 to 500 mS
<b>ID_XXX</b>	setting of the serial address
<b>PAS_XXXX</b>	setting of a password

### - Programming of the transformation ratio for the external CT's

For a good and right use of the present instrument it's necessary to program the transformation ratio of the current transformers used, with the front keys..

The transformation ratio of the CT is considered like the ratio between primary and secondary (example: with CT 1000/5, we must set in 200).

Once that the **SET** mode has been activated (led SET glows), press the **C** key and it will appear the message **CT**, (Current Transformer) and the transformation ratio value (set as 1 by the manufacturer), then select **set CT** (Current Transformer) in order to enter the transformation ratio value.

Keep the **B** key pressed to increase the value or the **A** key to decrease same (the variation will be made unit per unit), To speed up the operation keep the **B** or **A** keys pressed and the variation will be made by tens and hundreds successively. To stop the fast scrolling of values, you only need to stop pressing the selected key and to press it again, then the increase or decrease of values will return to a unit per unit variation.

Once that the selected value appears on the display, press the **C** key to confirm the setting, after this step the instrument is prepared for the next programming.

Shouldn't any key be pressed for over 8 seconds, the instrument will exit from the menu automatically, and the eventual setting **WON'T** be memorised.

#### **- Programming of the pulse weight**

The message **Pul** will appear on the display, so as the single pulse weight value, which can be set within 4 values:

Pul 0,01	1 pulse = 0,01 kWh / kVArh counted
Pul 0,1	1 pulse = 0,1 kWh / kVArh counted
Pul 1,0	1 pulse = 1 kWh / kVArh counted
Pul 10,0	1 pulse = 10 kWh / kVArh counted

Use the **A** and **B** keys to select the desired setting.

Press the **C** key to confirm and move to next programming.

#### **- Programming of pulse duration**

the message **PTL** will appear together with pulse duration value in mS to be set:

tpl 100	pulse duration: 100 mS
tpl 200	pulse duration: 200 mS
tpl 300	pulse duration: 300 mS
tpl 400	pulse duration: 400 mS
tpl 500	pulse duration: 500 mS

Use the **A** and **B** keys to select the desired setting.

Press the **C** key to confirm and move to next programming.

#### **- Programming of the address for the serial node**

This programming is only valid for those versions with the serial interface option.

The message **ID 001** will appear on the display. The programmable values go from 1 to 255. Press the **C** key to confirm and move to next programming.

For programming proceed as per the previously described procedure, such a value will identify the instrument when it is connected to an EIA 485 communication network.

#### **- Programming of a password**

This program voids any programming or cancellations of the energy counters by any unauthorised user.

The instrument is supplied with this feature unable (set as 0 = unable value), which allows to reach to **SETUP** and **RESET** of the counters.

The code programming goes from 2 to 9999. Once the password has been set, the password will be required for the next access to the **SETUP**, which will have to be entered in the previously described way, with the **A** and **B** keys, confirming with the **C** key. If the entered code is correct, it will be possible to reach the **SETUP**. Otherwise the message **PAS ERR** will appear during some seconds, and it will need to reach the **SETUP** with the **C** key as previously described.

After this setting the display returns to visualise **SETUP**.

#### **- Cancelling of energy counters**

When visualising the **SETUP** on the display, it is possible to reach the energy counters cancellation menu **RESET**, by pressing the **A** or **B** keys, confirming with the **C** key.

The cancellation is unique and brings all the four energy counters to zero: T1 kWh, T2 kWh, T1 kVArh, T2kVArh

After confirming with the **C** key, it appears the message **RES NO**

Press the **B** to change from **RES NO** to **RES yes**

Confirm with the **C** key. The message **RES ---** will appear, in order to advise that cancellation have been executed.

If no key has been pressed for over 8 seconds it will exit automatically from the cancellation menu.

**MENU FLOW**

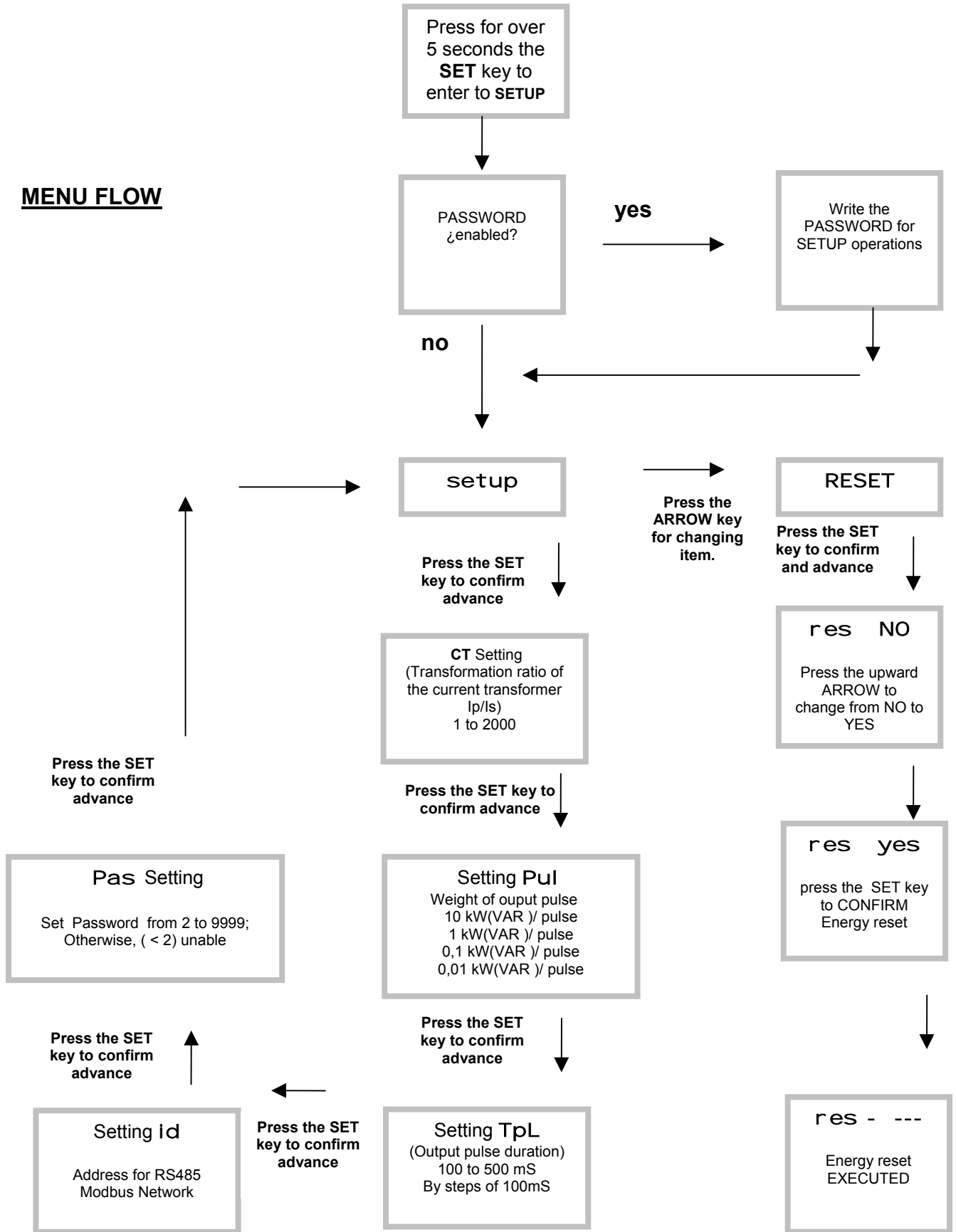

## MEASURES VISUALISATION

For a clear reading of the energies, these are visualised in a 7 characters display (kWhr/kVARhr) +1 (decimal)  
According with the switching status of the LED's kWh, kVARh, T1 and T2, the T1 y T2 time bands are shown, as per the following table:

Parameter	LED's STATUS			
	LED kWh	LED kVARh	LED T1	LED T2
Visualisation active energy T1time band. Energy counting on T1 time band.	SWITCHED ON	SWITCHED OFF	BLINKING	SWITCHED OFF
Visualisation active energy T2time band. Energy counting on T1 time band.	SWITCHED ON	SWITCHED OFF	BLINKING	SWITCHED ON
Visualisation active energy T1time band Energy counting on T2 time band.	SWITCHED ON	SWITCHED OFF	SWITCHED ON	BLINKING
Visualisation active energy T2time band Energy counting on T2 time band.	SWITCHED ON	SWITCHED OFF	SWITCHED OFF	BLINKING
Visualisation reactive energy T1time band Energy counting on T1 time band.	SWITCHED OFF	SWITCHED ON	BLINKING	SWITCHED OFF
Visualisation reactive energy T2time band. Energy counting on T1 time band.	SWITCHED OFF	SWITCHED ON	BLINKING	SWITCHED ON
Visualisation reactive energy T1time band Energy counting on T2 time band.	SWITCHED OFF	SWITCHED ON	SWITCHED ON	BLINKING
Visualisation reactive energy T2time band Energy counting on T2 time band.	SWITCHED OFF	SWITCHED ON	SWITCHED OFF	BLINKING

### NOTE regarding to the measures.

In some applications, in which the CT's secondary is connected to other instruments, different of the EMC-D3b counters, there might be some measuring problems, depending on the typology of the current inputs. Optionally, there are alternatives adapted to solve these possible problems.  
Please get in touch with the Technical Assistance Dpt., in case of problems.

### NOTE regarding digital inputs.

It is advisable to place a fast fuse 50mA 250V at the digital input.

The maximum absorbed current is 1 mA.

In absence of voltage at the input, the T1 time band will be selected.

With voltage applied to the input, the T2 time band will be selected.

Please refer to the technical characteristics for further information's regarding the digital inputs.

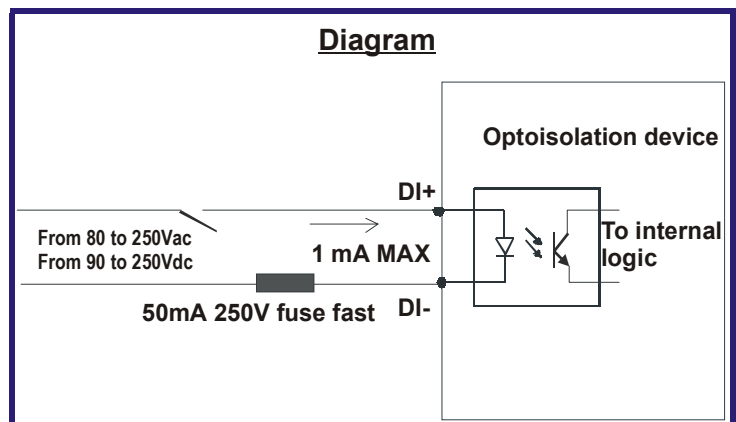

## TECHNICAL CHARACTERISTICS

MEASURES, ACCURACY	
Energy	Active and reactive energy in the three-phase system, with subdivision in two time bands Measuring range: 0 – 99999999,9 kWh (kVArh) Class 2 (IEC 1036) EN 61032-2
POWER SUPPLY, MEASURING INPUTS	
Auxiliary power supply	Standard 380-415V ±15% - Frequency 50-60Hz - absorption 3VA Voltage taken from voltage measuring inputs VL1 VL2
Voltage inputs	From 20 – 500 Vrms phase to phase (depending on the voltage power supply) ; permanent overload +20% - input impedance of 1 MΩ Wiring in three-phase systems, with 3 or 4 wires.
Current inputs	From 0,02 to 5A; permanent overload 30% - with external CT's with secondary 5A, primary programmable from 5 to 10000A - self-consumption <0,5VA
INPUTS / OUTPUTS	
Digital outputs	Two outputs with common, optomos 12÷230Vac/dc, max 150mA, Pulse Function: Weight programmable 0,01-0,1-1-10 kWh/pulse Pulse duration 100-200-300 400 500 milliseconds selectable dO1: active energy pulse output (accumulated T1+T2) dO2: reactive energy pulse output (accumulated T1+T2)
Digital Input	Changing time band function Optoisolated input: Insulation: 2500 Vrms 60 seconds Impedance: 440 kHom OFF voltage range (T1 selected) - 0 a 20 V ca/cc  ON voltage range (T2 selected) - From 80 Vac to 250 Vac, 50/60Hz - From 90 Vdc to 300Vcc, polarised.
Serial output	One optional output RS485, 9600 baud's, MODBUS-RTU protocol
GENERAL	
Display, operation keys	1 display with red LED's of 7,5 mm, made by 8 digits of 7 segments 6 LED's of 3mm, for indicating about the visualisation mode 3 push-button keys for selecting measures and programming
Mechanics	Protection degree: IP52 frontal - IP20 casing and terminals - weight: 0,5 kg approx. Connections made through screw terminals for cross section wires of 2,5 mm <sup>2</sup> Self-extinguishing plastic enclosure (Casing) for DIN rail 35mm mounting, with dimensions of 6 modules of 17,5mm.
Environmental	Working temperature: -10÷60°C; relative humidity <90% Stocking temperature: -25÷70°C Insulation test: 3 kV during 1 minute
Standards of reference and Marking	CEI EN 50081-2; CEI EN 61000-6-2; CEI EN 61010-1; CEI EN 61036-2



## DIMENSIONS

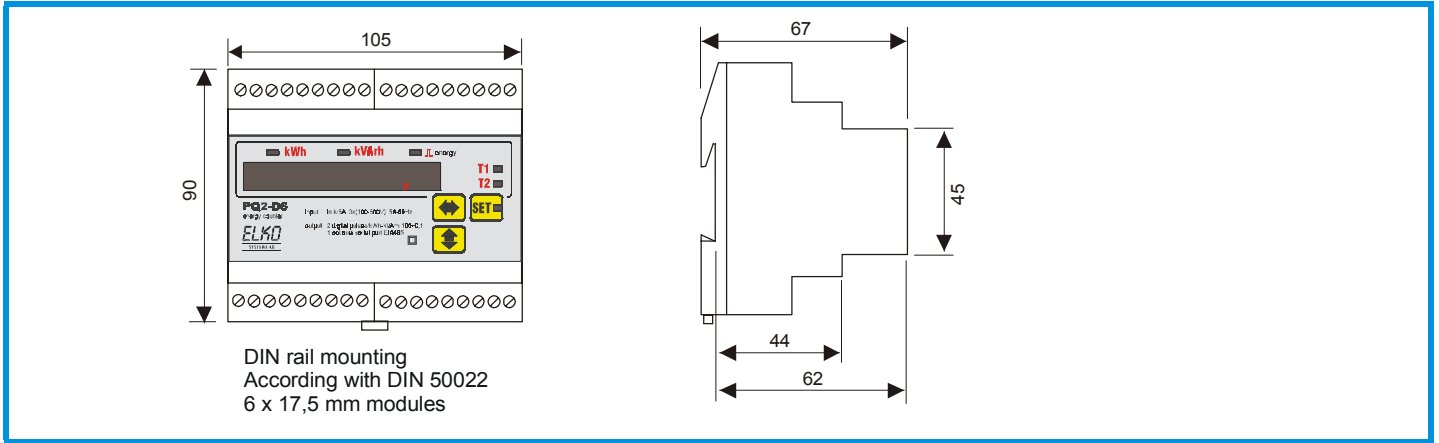

For applications that have not been described within the present manual, please refer to the specific documentation or contact with the Technical Assistance Department.

### NOTE:

Based on the Standards and products evolution, the Company reserves itself the right to modify, at any time, the characteristics of the product, described within the present manual. Bearing on mind that they are always verified. The manufacturer's liability due to the product's defects, " might be reduced or null (...) whenever the damage is jointly caused by a product's defect / by the person subject of the damage or by a dependant, whose the damaged subject is responsible" (Article 8, 85/374/CEE)

 **control** elettronica srl

26900 LODI - ITALY - Via San Fereolo, 9  
tel. (0371) 30207-30761-35386 fax (0371) 32819 E-mail: [control@control.it](mailto:control@control.it)