



MOVING-IRON AMMETER WITH CHANGE OVER SWITCH



72AS, 96AS

For measuring of line current in 3-phase networks.
The scale is calibrated according to the primary current.

ATTENTION!

The instrument can only be used with current transformer!

Technical data

Movement: Moving-iron movement with spring-type oil filled bearings, practically vibration-free oil damping.

Class of accuracy: ±1.5 %

Permanent overload: 1.2 - fold current.

Scale length: -type 72AS 62 mm
-type 96AS 102 mm

Frequency range: 15 ... 50 ... 100 Hz.

Instrument case: Made of non-flammable plastic acc. to UL 94-V1

Weight: max. 0.4 kg for types 72AS
max. 0.5 kg for types 96AS

Fixing elements: plastic clips



AMMETER	
Positions:	L1 L2 L3 OFF
Measure range:	.../1A or .../5A

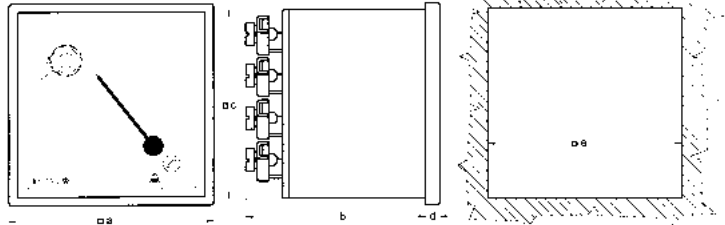

Type	Dimensions (in mm.)				
	a	b	c	d	e
96 AS	96	54	90	5	92+0.8
72 AS	72	54	66	5	68+0.7

Scales for CT. use				
Primary current of the CT				
1A	40 A	150 A	750 A	2000 A
5A	50 A	200 A	800 A	2500 A
10 A	60 A	250 A	1000 A	3000 A
15 A	75 A	300 A	1200 A	4000 A
20 A	80 A	400 A	1250 A	5000 A
25 A	100 A	500 A	1500 A	6000 A
30 A	125 A	600 A	1600 A	

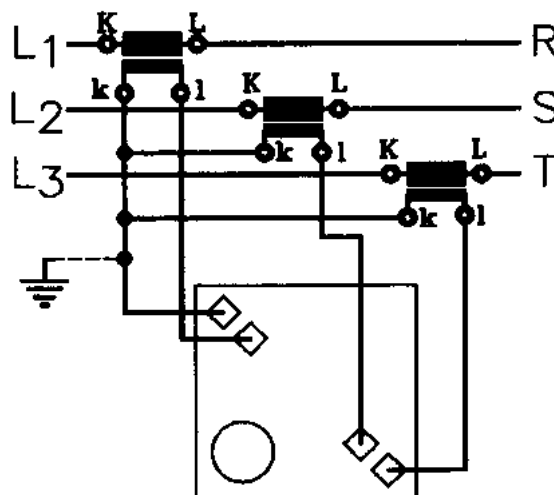
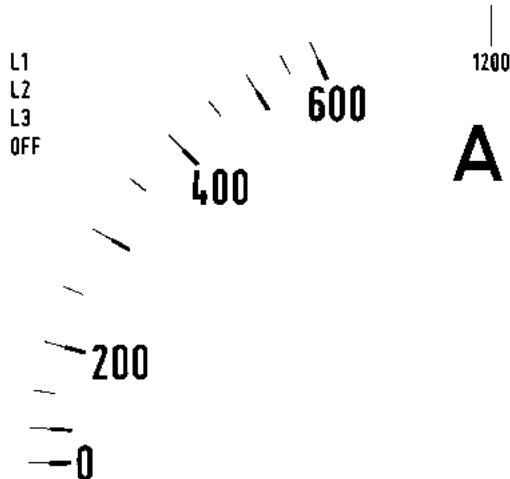

Order specification:

- Moving-iron ammeter with change over switch.
- Frame dimensions: **96x96 mm**
- Current range: **5A**
- Current transformer ratio: **250/5A**

Ordering data:

- Moving-iron ammeter with change over switch.
- type: **96AS**
- CT: **250/5A**
- scale: **250(500)A**