



48cD..., 72cD..., 96cD...144cD

For measuring DC current or voltage

Types 72cD... and 96cD... are with interchangeable scale

Technical data:

Movement: Moving-coil
with pivot spring type bearing

Instrument case: steel-plate/ (144 cD.. plastic)
On request voltmeters as well as ammeters
up to 8 A will be supplied with plastic terminal cover

Scale length: 72 mm/48cD...,109 mm/ 72 cD...,
140mm/96cD...,230mm/144 cD

Permanent overloading: 1.2 fold current
respective voltage

Class of accuracy: 1.5

Protection: casing IP50; terminals IP00

Weight: 0.25 kg /48cD...; 0.35 kg /72cD...;
0.5 kg /96cD..., 0.8 kg /144cD

Fixing elements: with two spring-type fastening clips
DIN 43835 "A" / (plastic clips for 144 cD..)



AMMETERS		Metal case			Plastic case
Frame dimensions		48x48 mm	72x72 mm	96x96 mm	144x144 mm
Measuring range	Cat No.	Type: 48cDA	Type: 72cDA	Type: 96cDA	Type: 144cDA
		2115-12-...	2038-12-...	2039-12-...	2561-12-...
		Internal Resistance [Ω]	Internal Resistance [Ω]	Internal Resistance [Ω]	Internal Resistance [Ω]
100 μA	001	6200	6200	6200	6200
250 μA	005	2350	2350	2350	2350
1 mA	011	380	380	380	380
5 mA	018	8	8	8	8
10 mA	021	20	20	20	20
20 mA	024	4	4	4	4
25 mA	025	2.4	2.4	2.4	2.4
100 mA	031	0.6	0.6	0.6	0.6
500 mA	038	0.12	0.12	0.12	0.12
1 A	041	0.06	0.06	0.06	0.06
1.5 A	043	0.04	0.04	0.04	0.04
2.5 A	045	0.024	0.024	0.024	0.024
4 A	047	0.015	0.015	0.015	0.015
5 A	048	0.012	0.012	0.012	0.012
6 A	049	0.01	0.01	0.01	0.01
4...20 mA	501	80	80	80	80
*...A / 50 mV	C01	10	10	10	10
*...A / 60 mV	C01	12	12	12	12
*...A / 100 mV	C01	20	20	20	20
*...A / 150 mV	C04	30	30	30	30
*...A / 300 mV	C05	60	60	60	60

* For connection to separate (S-1 type, 60 mV) shunt The calibration of the instruments 0.035 Ω lead-wire (=2x1 m Ø1 mm²) is taken into consideration.

The tolerance of the internal resistance is generally ±20%

Note: on request types different from tables are accepted.



MOVING-COIL INSTRUMENTS WITH 240° CIRCULAR SCALE



VOLTMETERS		Metal case			Plastic case
Frame dimensions		48x48 mm	72x72 mm	96x96 mm	144x144 mm
Measuring range	Cat No.	Type: 48cDV	Type: 72cDV	Type: 96cDV	Type: 144cDV
		2115-12-...	2038-12-...	2039-12-...	2561-12-...
		Internal Resistance	Internal Resistance	Internal Resistance	Internal Resistance
1 V	101	1000 Ω/V ↓	1000 Ω/V ↓	1000 Ω/V ↓	1000 Ω/V ↓
1.5 V	103				
2.5 V	105				
4 V	107				
6 V	109				
10 V	111				
15 V	113				
20 V	114				
25 V	115				
30 V	116				
40 V	117				
50 V	118				
60 V	119				
80 V	120				
100 V	121				
150 V	123				
200 V	124				
250 V	125				
300 V	126				
400 V	127				
500 V	128				
600 V	129				

Note: On request orders for types with zero in the middle are accepted. On request types different from tables are accepted.

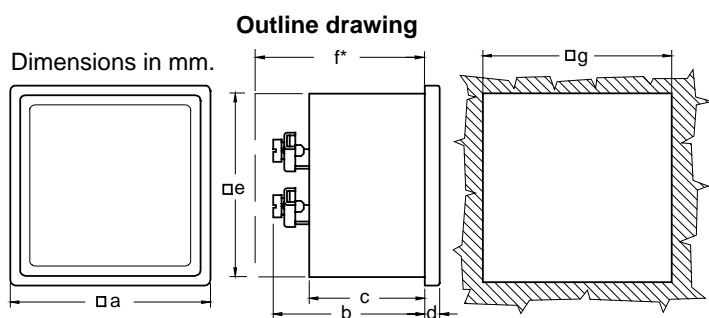

Type	Dimensions (in mm.)						
	a	b	c	d	e	f*	g
48cD..	48	70	55	5	44	71	45 ^{+0,6}
72cD..	72	60	51	5.5	66	76	68 ^{+0,7}
96cD..	96	60	51	5.5	90	76	92 ^{+0,8}
144cD..	144	59	47	7	137	---	138 ⁺¹

* with terminal cover

Scales M=1:1

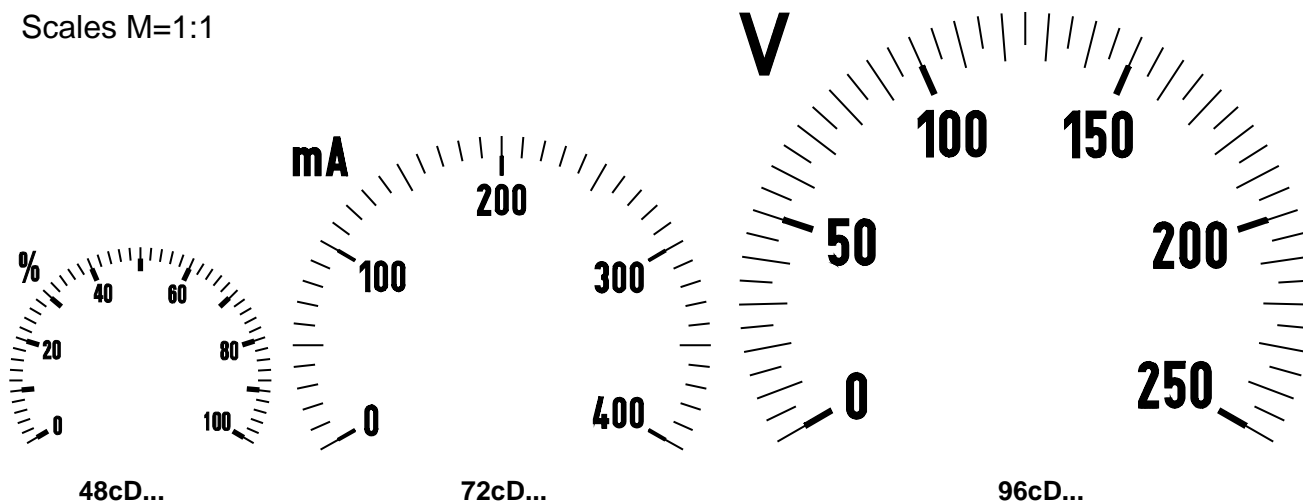

Order specification:

- Moving-coil ammeter with 240° circular scale
- Frame dimension: 72x72 mm
- Measuring range: 1 mA

Ordering data:

- Moving-coil ammeter with 240° circular scale
- Type: 72cDA
- Cat No.: 2038-12-011