



FEMA ELECTRÓNICA, S.A.

SERIE : VIR-30 Model : 30-31

FUNCTION : INDICATOR FOR PROCESS SIGNAL

Data Sheet:

83/93

REV. 2509/01

INSTRUMENT FOR PROCESS SIGNAL

FRONT VIEW

DECIMAL POINT SELECTION, INSTALL THE JUMPER PUSH-ON WHERE NEEDED

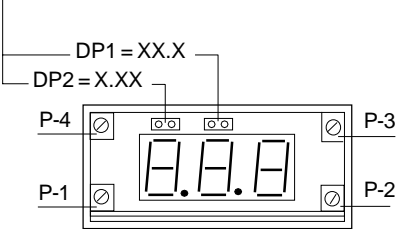

- P1 : ZERO ADJUSTMENT (± 10 POINTS).
- P2 : SPAN (± 5 % OF RANGE).
- P3 : GAIN ADJUSTMENT
- P4 : OFFSET adjust

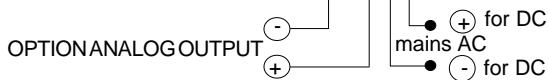
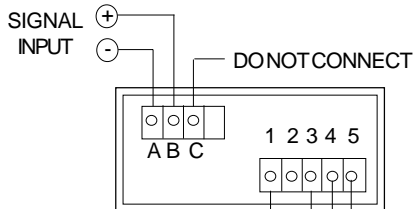

GENERAL SPECIFICATIONS

DISPLAYS	RED LED, 14,2 mm. (0,56")
DISPLAY RANGE	FROM -99 TO +999
POLARITY	AUTOMATIC ONLY "-"
OVERRANGE	POSITIVE "EEE" NEGATIVE " --- "
DECIMAL POINTS	PROGRAMMED BY JUMPERS ACCESSIBLE BEHIND THE LENS
READ RATE	4 / S.
TEMP CO	125 ppm
STANDARD POWER	230 Vac 50 Hz
POWER CONSUMPTION	3,5 W.
ISOLATION	2 KV.
ELECTRICAL CONNECTION	SCREW-CLAMP CONNECTORS
SIZE	DIN 43700
COLOUR	BLACK, ABS
WEIGHT	150 GRAMME

OPTION HOLD.- Connect terminal 2 to terminal 3

Terminal 1, 2 and 3 are only when the options analog output or hold are ordered.

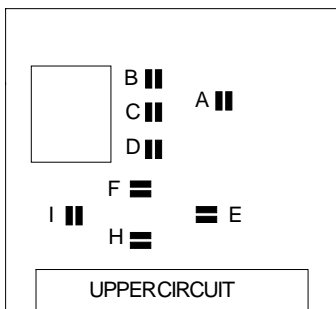

SELECTION OF : SIGNAL INPUT AND OFFSET

MODEL	SIGNAL INPUT	CLOSE JUMPER	OFFSET		EXCURSION OF	
			POS.	NEG.	OFFSET (P4)	SPAN (P2)
30	4 - 20 mA.	A - C - D - E	F	H	± 5 % OF RANGE OVER 0 CENTRAL	from 100 to 999
	10 - 50 mA.					
	1 - 5 Vcc.	B - E				
31	0 - 20 mA.	A - C - D - E - I	-----		from 0 to 999	
	0 - 1 mA.	A - C - I				

MECHANICAL DIMENSIONS

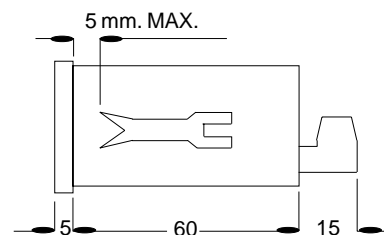
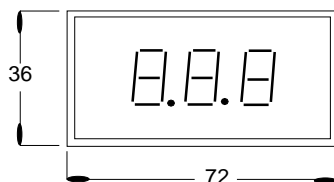
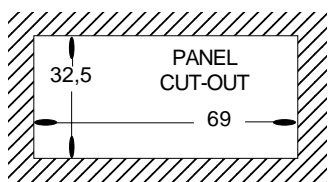

INSTALLATION

PRECAUTIONS



The installation and the future use of this unit must be done by suitably qualified personnel. This unit has not AC (mains) switch, neither internal protection fuse, it will be in operation as soon as power is connected. The installation must incorporate an external mains switch with a protection fuse, except for Serie BDF which has the fuse installed. The value of the fuse is indicated on the tables below. This unit can operate with Vac or Vdc, verify that the proper power option is installed for the power to be used.

SAFETY PRESCRIPTIONS



The unit has been designed and tested under UNE 20553 rules and is delivered in good condition. This data sheet contains useful information for electrical connections. Do not make wiring signal changes or connections when power is applied to the unit. Make signal connections before power is applied and, if reconnection is required, disconnect the AC (mains) power before such wiring is attempted. The unit cannot be installed in open places. Do not use until the installation is finished.

POWER SUPPLY



The power supply must be connected to the adequate terminals (see the connection instructions) The characteristics of the power supply are showed on the side label. Please make sure that the unit is correctly connected to a power supply of the correct voltage and frequency. Do not use any other power supply otherwise permanent damage may be caused to the unit. Do not connect the unit to power sources heavily loaded or to circuits which power loads in cycle on-off or inductive loads.

WARNING: If the power supply is DC voltage, be careful with the polarity indicated for each terminal. (see the connection instructions).

SAFETY CONSIDERATIONS

PRESCRIPTIONS



Before starting any operation of adjustment, replacement, maintenance or repair, the unit must be disconnected from any kind of power supply. Keep the unit clean, to assure good functioning and performance, use for it a clean and humid rag. Do not use abrasive products, solvents, alcohol, etc... to clean the red filters and plastic parts of the unit. To prevent electrical or fire hazard, do not expose the unit to excessive moisture. Do not operate the unit in the presence of flammable gases or fumes, such an environment constitutes a definite safety hazard. The unit is designed to be mounted in a metal panel. If the unit shows signs of damage, or is not able to show the expected measures, or has been stored in a bad conditions or a protection failure can occur, then do not attempt to operate and keep the unit out of service.

IN CASE OF FIRE

- 1.- Disconnect the unit from the power supply.
- 2.- Give the alarm according to the local rules.
- 3.- Switch off all the air conditioning devices.
- 4.- Attack the fire with carbonic snow, do not use water in any case.

WARNING: In closed areas do not use systems with vaporized liquids.

RECOMMENDED FUSES FOR EACH SERIE OR MODEL

Power Supply	230 Vac	115 Vac	24 Vdc
Series : VIR-30	50mA	100mA	

CE DECLARATION OF CONFORMITY

Manufacturer: **FEMA ELECTRÓNICA, S.A.**
Address : Centro Industrial Santiga
c\Altimira, 14 (Talleres 14 - Nave 2)
E-08210 - Barberà del Vallès
SPAIN

DIRECTIVES:

EUROPEAN DIRECTIVE FOR LOW VOLTAGE D73/23/CEE AMENDED BY D93/68/CEE
Equipments powered from 50 to 1000 Vac. and / or from 75 to 1500 Vdc.

ELECTROTECHNICAL REGULATION FOR LOW VOLTAGE (RBT) ITC 21, ITC 29, ITC 35.
Equipments with power supply lower than 50 Vac. and/or 75 Vdc.

Conforming products :

EUROPEAN DIRECTIVE FOR ELECTROMAGNETIC COMPATIBILITY D89/336/CEE AMENDED BY D93/68/CEE

Series : VIR-30
Models : 01, 03, 04, 05, 06, 08, 10, 15, 20, 21, 30, 31, 33, 51,90

STANDARDS:

IMMUNITY
UNE EN 50082-1 (1997)

We hereby declare that the above products conform to the essential protection requirements of Directives and Harmonised Standards stated below.

EMISSIONS
UNE EN 50081-1 (1993)

ELECTRICAL SAFETY
UNE EN 61010-1 (1996)
UNE EN 60204-1 (1997)

Signed : Alex Pina
Position : Quality Manager
Place and Date : Barberà del Vallès, 2001

Recommendations

The panel meters of the current series have been designed in order to be mounted on metal panels, connected to earth.

NEVER lay together signal cables with power supply cables, through the same channel.

Whenever electromagnetic compatibility is an issue, use shielded cables, for both signal and power supply cables.

It is recommended to let the power supply cables go through a ferrite. If possible, let the cable cross twice through the ferrite, and maintain the ferrite the closest possible to the instrument.

It is recommended to let the signal cables go through a ferrite. If possible, let the cable cross twice through the ferrite, and maintain the ferrite the closest possible to the instrument.

Connect the shields of the signal cable and power supply cable to the metallic panel, which is at his side connected to earth.

Notes:

If electromagneteic interferences are atill an issue, try one or more of the following indications :

- use conectors with metallic shields when need to connect periferics to the system. Connect the shield of the cable to the shield of the connector.
- disconnect the cable shield of the power supply or/and signal cables.
- if your instrument is powered with direct current (DC), connect the negative terminal of the DC power, to the earth plug of the instruments power supply clamp.
- use a larger ferrite in the signal and/or the power supply cables.
- make the signal and/or power supply cables the shortest possible.