

# ACTIVE HUMIDITY AND HUMIDITY-TEMPERATURE TRANSMITTERS WITH CONFIGURABLE TEMPERATURE WORKING RANGE

## Description

The HD 2011T... and HD 2012T... are microprocessor-controlled active humidity and humidity-temperature transmitters. The temperature range is configurable.

These transmitters convert the humidity and temperature values into two linear current or voltage signals. Linearisation, with a digital technique, allows excellent precision and stability to be obtained. Each output of the transmitter may be selected between 0...20mA, 4...20mA or 0...10V and is set by means of a jumper.

The absence of trimmers, potentiometers, etc. makes instrument calibration very simple: all that is required is to press a key while a led indicates any abnormal situations. The humidity input can be recalibrated using two saturated solutions: the first with 75%R.H., the second with 33%R.H. The relative humidity range 0%R.H...100%R.H. is fixed: depending on the solution used, the value 0%R.H. corresponds to 0mA, 4mA or 0V, while 100%R.H. corresponds to 20mA, 1V or 10V. In the HD 2012 model, the user can set the temperature output in any range in the field -50...+200°C as long as the minimum amplitude is at least 25°C; a led indicates any alarm situations (temperature outside the set range, temperature sensor broken or short circuiting) and assists the user in the programming phase.

**Important note:** the relative humidity sensor can work in the temperature range -40...+150°C. Beyond this range the transmitter can work till +180°C for brief periods or in a special execution

## Technical data (@ 20°C and 24Vac)

		HD 2011T...	HD 2012T...
Relative humidity input	Sensor model		MK 33
	Capacity		300pF typ.
	Accuracy at 20°C		±2% (5...90%) (±2.5% in the remaining field)
	Relative humidity work range		5...98%R.H.
	Temperature work range of the relative humidity sensor		-40...+150°C - compensated
	Cable length		TC Version = 1.5 m, 5 m and 10 m
	Sensor maximum static working pressure		20bar
<b>During use, check the compatibility of the sensor with the atmosphere in which it is installed</b>			
Temperature input	Sensor	----	Pt100, 100Ω at 0°C (α=0.00385)
	Connection	----	with 3 (o 2) leads
	Energising of the transducer	----	<1mA
	Configurable measurement range	----	-50...+200°C
	Accuracy at 20°C	----	±0.1°C±0.1% of the reading
Output	4...20mA R.H. 0...20mA R.H. 0...10Vdc R.H. (**)	0...100%R.H.	0...100%R.H.
	4...20mA Temp. 0...20mA Temp. 0...10Vdc Temp. (**)	----	Configurable in the range -50...+200°C (minimum amplitude: 25°C)
	22mA	In case of incorrect programming, probe disconnected or temperature out of the set range. The red alarm Led lights up. (***)	
	Linearisation	Digital	
Power supply	Voltage / Absorption	24Vac ±10%, 50...60Hz (on request 230Vac) / 3VA	
	Cable grommet	PG7 - maximum cable diameter 6 mm	
Load	Current output	Load resistance ≤ 500Ω	
	Voltage output	Load resistance ≥ 100KΩ	
Response time (τ)	Without filter	6 seconds	
	With filter	3 minutes	
Electronics working temperature		-10...+70°C	
Electronics protection class		IP 67	

(\*) Time required to reach 63% of the final variation

(\*\*) The outputs 0...1Vdc and 0...5Vdc are available on request

(\*\*\*) If the measured temperature T goes out of the set range T1...T2 (T1<T2), the temperature transmitter keeps 4mA for T<T1 and 20mA for T>T2 for a dead band of 10°C before going into error status at 22mA.

## Installation and connection

Figure 3,4,5 show the mechanical dimensions of the transmitters.

Figures 1 and 2 show the wiring diagram of the transmitters configured with the current output. The load represents any device inserted in the current loop, that is: an indicator, a controller, a data logger or a recorder.

The relative humidity measurement precision does not depend on the position of the transmitter. However it is advisable to install the transmitter in such a way that the sensor is facing downwards to minimise the accumulation of dust on the filter that protects the sensor. The transmitter must not be installed in the vicinity of a source of heat or cold, since heating

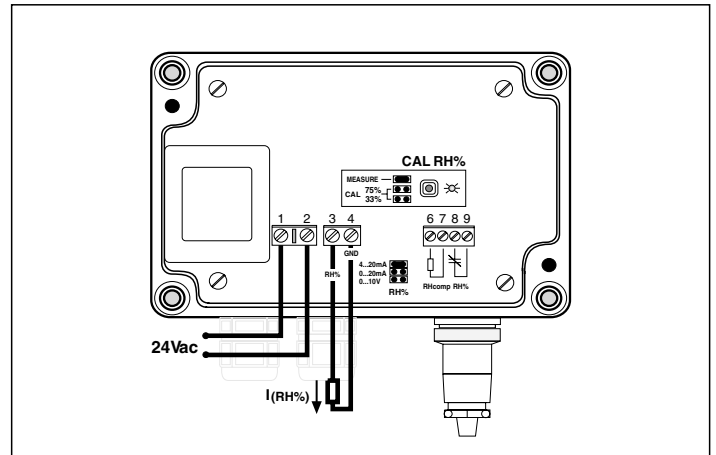


Fig. 1 Wiring diagram of the single relative humidity transmitter with current output.

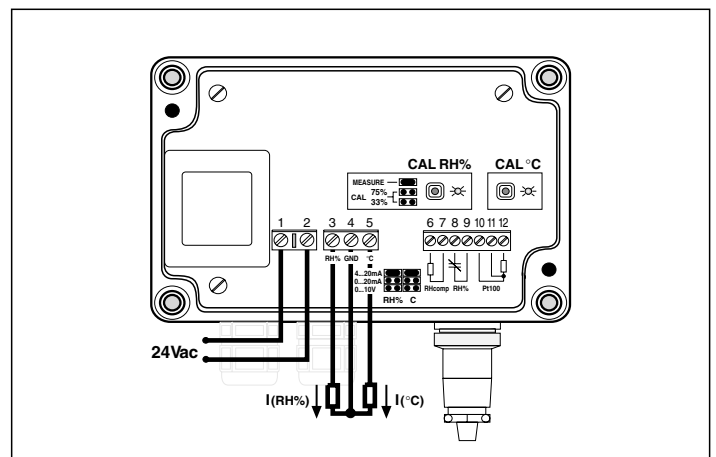
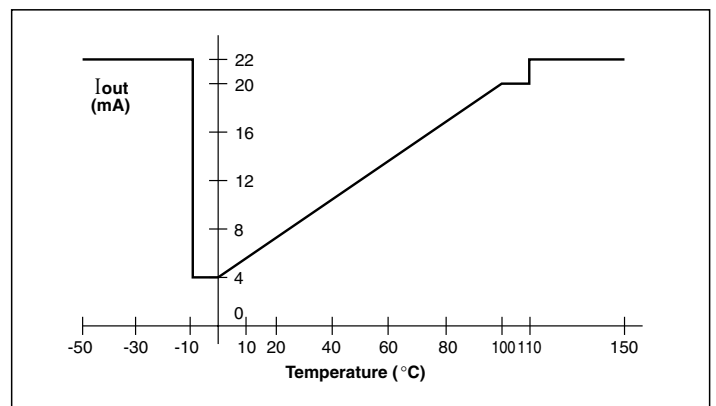
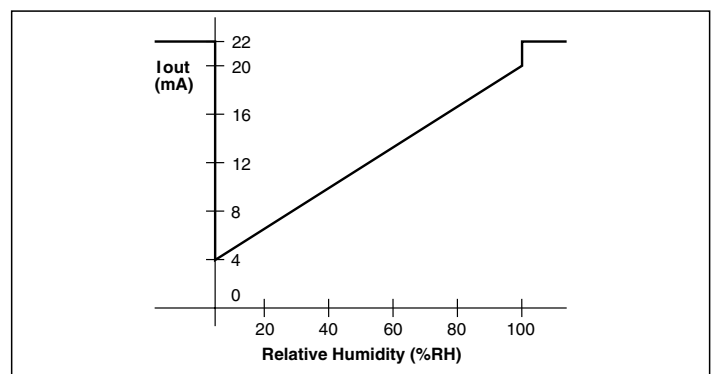


Fig. 2 Wiring diagram of the double transmitter: relative humidity and temperature with current output.



Example of 4-20mA temperature output. Range 0...100°C.



Example of 4-20mA relative humidity output.

or cooling of the air cause a decrease or an increase of the relative humidity (with the same amount of water vapour present), near doors, in the presence of draughts or in areas where there is no movement of air.

**During use, check the compatibility of the sensor with the atmosphere in which it is installed.**

#### Assembly

The instrument is offered in three different configurations to satisfy every application requirement. These are:

**TO** horizontal version, generally for installation in a channel; a sliding joint is available for fixing in channels or on walls with a 1/2" gas thread;

**TV** vertical version for installation on the wall;

**TC** version with cable. The probe is connected to the electronics by means of a cable of various lengths and it may operate in a temperature range of -40...+150°C.

**Attention: in TC models the sensor and the electronics have the same serial number, they cannot be exchanged with other transmitters unless the instrument is recalibrated in line with the new probe.**

#### Programming

The transmitters of the series HD 2011T... and HD 2012T... are equipped with a calibrated relative humidity probe and temperature probe. The humidity and temperature outputs can each be selected, independently, with a jumper between 0mA...20mA, 4mA...20mA or 0V...10V. **When it leaves the factory the transmitter is already set as follows:**

<b>Relative humidity</b>	4mA → 0%R.H.	20mA → 100%R.H.
<b>Temperature</b>	4mA → 0°C	20mA → 100°C

The user can recalibrate the humidity probe, as long as he maintains the correspondence 4mA (or 0mA or 0V) = 0%R.H. and 20mA (or 10V) = 100%R.H. while he can set a different range for the temperature output (-50...+200°C).

#### A) Calibration of the humidity probe

The following procedure refers to the output set for a current of 4...20mA: for the other outputs it is sufficient to shift the jumper before starting the calibration operation.

The following accessories are required:

- a source of alternating power supply at 24Vac or 230Vac depending on the models (check the data on the plate);
- a precision ammeter with a minimum range 0÷25mA.

Calibration of the humidity probe is carried out on two fixed points: **the first point is always 75.4%R.H. and the second point is always 33%R.H.**, proceeding as follows:

- supply power to the instrument as shown in the wiring diagrams in Fig.1 (HD 2011T...) and Fig.2 (HD 2012T...);
- insert the probe in the container with the 75%R.H. saturated solution and **wait at least 30 minutes;**
- move the jumper from "MEASURE" position to "CAL 75%" position;
- press the key marked "Program switch R.H." and **hold it down for at least 5 seconds** until the corresponding led starts to blink. At this point it is possible to release the key: the led remains lit. A sensor inserted in the probe compensates the temperature difference of the solution with respect to 20°C;
- insert the probe in the container with the 33%R.H. and **wait at least 30 minutes;**
- move the jumper to "CAL 33%" position;
- press the key marked "Program switch R.H." and **hold it down for at least 5 seconds** until the corresponding led goes out. At this point it is possible to release the key, the ammeter will indicate a current of 9.28mA if the solution is at 20°C. If the solution is at a different temperature, the current indicated by the ammeter will be equal to the value shown in the following table:

°C	10	15	20	25	30	35	40	45	50
%R.H.	33.4	33.3	33	32.7	32.4	32	31.6	31.1	30.5
mA	9.34	9.33	9.28	9.23	9.18	9.12	9.06	8.98	8.88

- return the jumper to "MEASURE" position. This concludes calibration of the R.H. probe.

**Important note: the first calibration point must always be 75%R.H.**

#### B) Programming the temperature output 4-20mA for HD 2012T... models

The following procedure refers to the output set for a current of 4...20mA: for the other outputs it is sufficient to shift the jumper before starting the calibration operation.

The following accessories are required:

- a source of alternating power supply at 24Vac or 230Vac depending on the models (check the data on the plate);
- Pt100 calibrator or a set of precision resistances;
- a precision ammeter with a minimum range 0...25mA.

#### Procedure

- Connect the temperature section of the HD 2012T... as shown in Fig.2, set the Pt100 calibrator at the temperature corresponding to 4mA. For example, supposing you want to set the range -10...+120°C, the calibrator will be set at -10°C: the equivalent resistance value will be 96.09Ω; if calibration is performed with a fixed resistance, a fixed resistance with a value of 96.09Ω will be connected between the terminals 11 and 12, with the terminals 10 and 11 short circuiting.
- Wait 10 seconds until the measurement has stabilised, **hold down "Program switch °C" for at**



Holder HD 9008.21.2 + HD 9008.26/14 125 mm.



Holder HD 9008.21.1 + HD 9008.26/14 250 mm.



Flange with sensor block HD 9008.31

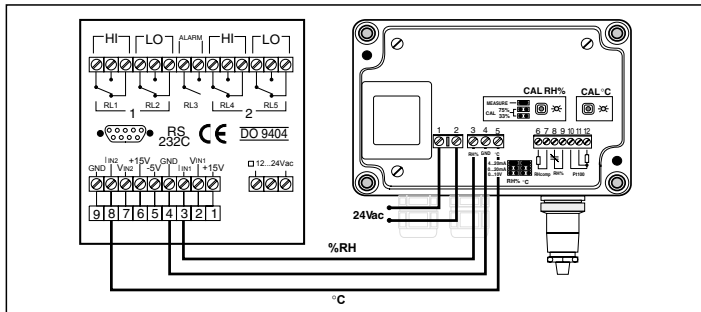
**least 5 seconds** until the LED blinks once and remains lit.

- Set the Pt100 calibrator at the temperature value contemplated for 20mA. According to the example above, the calibrator will be set at +120°C: the equivalent resistance value will be 146.07Ω; if calibration is performed with a fixed resistance, a fixed resistance with a value of 146.07Ω will be connected between the terminals 11 and 12, with the terminals 10 and 11 short circuiting.
- Wait 10 seconds until the measurement has stabilised, **hold down "Program switch °C" for at least 5 seconds** until the LED goes out. When the key is released the led blinks twice to confirm that programming has been completed. At this point the procedure is ended.
- Check that the setting corresponds to the required specifications, setting the calibrator (or connecting the precision resistances) at the values corresponding to 4 and 20mA and checking the current in the ammeter.

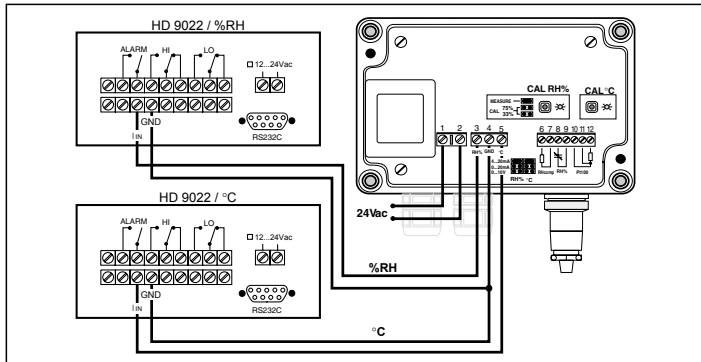
**Order codes**

- HD 2011 TO/1:** Active relative humidity transmitter, output 0...20mA, 4...20mA or 0...10V. Horizontal fixed probe for channel installation L=130 mm.
- HD 2011 TO/2:** Active relative humidity transmitter, output 0...20mA, 4...20mA or 0...10V. Horizontal fixed probe for channel installation L=330 mm.
- HD 2011 TO/3:** Active relative humidity transmitter, output 0...20mA, 4...20mA or 0...10V. Horizontal fixed probe for channel installation L=530 mm.
- HD 2011 TV:** Active relative humidity transmitter, output 0...20mA, 4...20mA or 0...10V. Vertical fixed probe for wall installation
- HD 2011 TC/1:** Active relative humidity transmitter, output 0...20mA, 4...20mA or 0...10V. Probe L=130 mm for direct connection to the instrument with a cable L=1.5 metres.
- HD 2011 TC/2-5:** Active relative humidity transmitter, output 0...20mA, 4...20mA or 0...10V. Probe L=330 mm for direct connection to the instrument with a cable L=5 metres.
- HD 2011 TC/2-10:** Active relative humidity transmitter, output 0...20mA, 4...20mA or 0...10V. Probe L=330 mm for direct connection to the instrument with a cable L=10 metres.
- HD 2012 TO/1:** Double active relative humidity and temperature transmitter for channel installation, double output 0...20mA, 4...20mA or 0...10V. Horizontal fixed probe for channel installation L=130 mm.
- HD 2012 TO/2:** Double active relative humidity and temperature transmitter for channel installation, double output 0...20mA, 4...20mA or 0...10V. Horizontal fixed probe for channel installation L=330 mm.
- HD 2012 TO/3:** Double active relative humidity and temperature transmitter for channel installation, double output 0...20mA, 4...20mA or 0...10V. Horizontal fixed probe for channel installation L=530 mm.

**Examples of connection of the transmitters HD 2011T... and HD 2012T... with the indicators HD 9022 and DO 9404**

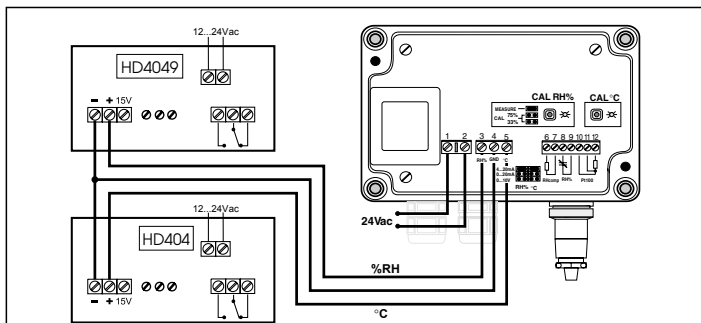


**Fig. 11** HD 2012T... configured with current output 4...20mA connected to the double indicator regulator DO 9404.



**Fig. 12** HD 2012T... configured with current output 4...20mA connected to two indicator regulators HD 9022.

**Examples of connection of the transmitters HD 2011T... and HD 2012T... with the indicators HD 404 and HD 4049**

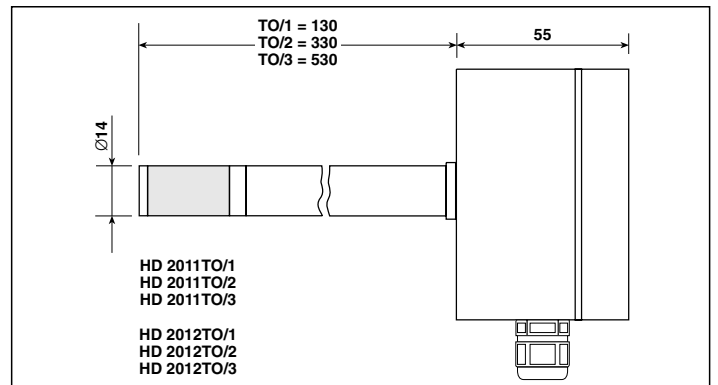


The **Temperature** configuration of the transmitter HD 2012T... has to be the same as the HD 404: 4mA = -20°C...20mA = +80°C.

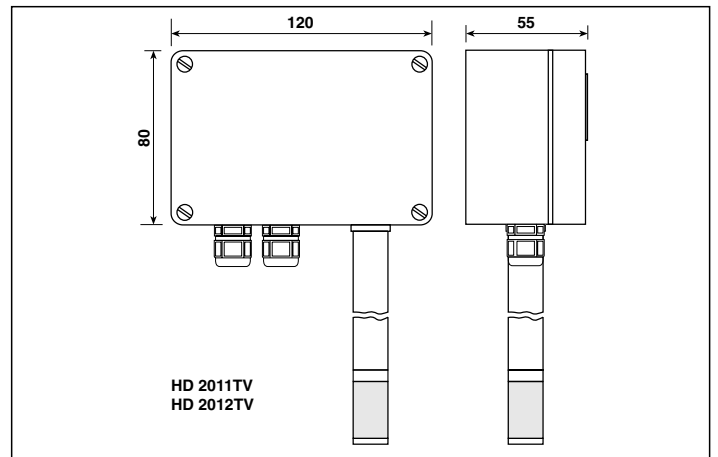
**Fig. 14** HD 2012T... configured with current output 4...20mA connected to a relative humidity regulator HD 4049 and to a temperature regulator HD 404 - HD 2012T...

- HD 2012 TV:** Double active relative humidity and temperature transmitter, double output 0...20mA, 4...20mA or 0...10V. Vertical fixed probe for wall installation.
- HD 2012 TC/1:** Double active relative humidity and temperature transmitter for channel installation, double output 0...20mA, 4...20mA or 0...10V. Probe L=130 mm for direct connection to the instrument with a cable L=1.5 metres.
- HD 2012 TC/2-5:** Double active relative humidity and temperature transmitter for channel installation, double output 0...20mA, 4...20mA or 0...10V. Probe L=330 mm for direct connection to the instrument with a cable L=5 metres.
- HD 2012 TC/2-10:** Double active relative humidity and temperature transmitter for channel installation, double output 0...20mA, 4...20mA or 0...10V. Probe L=330 mm for direct connection to the instrument with a cable L=10 metres.
- HD75:** saturated salt solution 75% R.H. with adapter M 12x1
- HD33:** saturated salt solution 33% R.H. with adapter M 12x1
- HD9008.21.1:** holder for vertical sensor, wall distance 250mm, hole Ø 26. Use with reduction HD9008.26.14
- HD9008.21.2:** holder for vertical sensor, wall distance 125mm, hole Ø 26. Use with reduction HD9008.26.14
- HD9008.26/14:** reduction for Ø 26 and Ø 14mm holes, for HD9008.21.1 and HD9008.21.2
- HD9008.31:** flange with sensor block Ø 14mm for duct sensors of the series TC and TO.

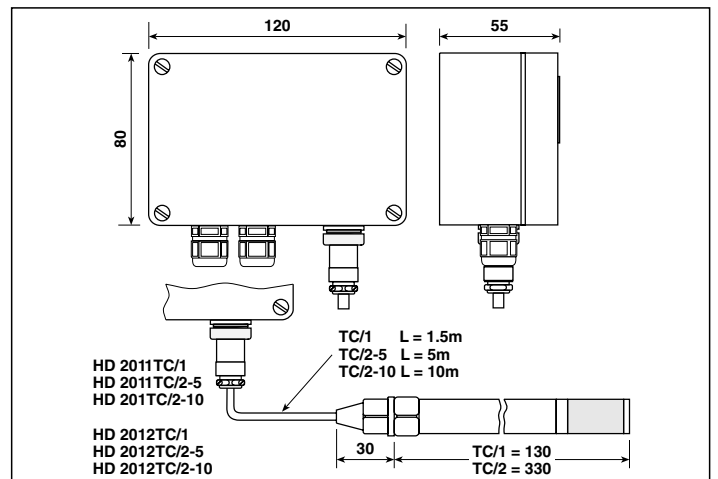
On request the transmitters can be supplied with voltage output 0...1Vdc or 0...5Vdc.



**Fig. 7** Mechanical dimensions version TO.



**Fig. 8** Mechanical dimensions version TV.



**Fig. 9** Mechanical dimensions version TC.